

EXCELLENCE 800

VHP 12



OPERATING
INSTRUCTIONS
INSTRUCTIONS
DE SERVICE

Ergoline

Ergoline Excellence

834480 / Index „_“ / us / fr / 10.2004

Operating Instructions Instructions d'utilisation

USA

F

Excellence 800 Turbo Power
VHP 12

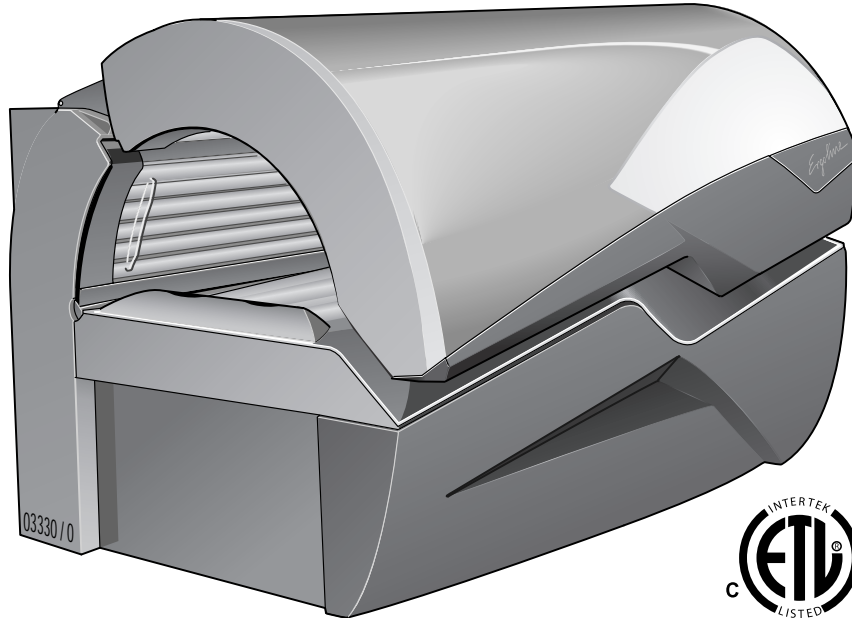

USA Operating Instructions 3

F Instructions d'utilisation 91

Ergoline Excellence

Operating Instructions



Excellence 800 Turbo Power
VHP 12

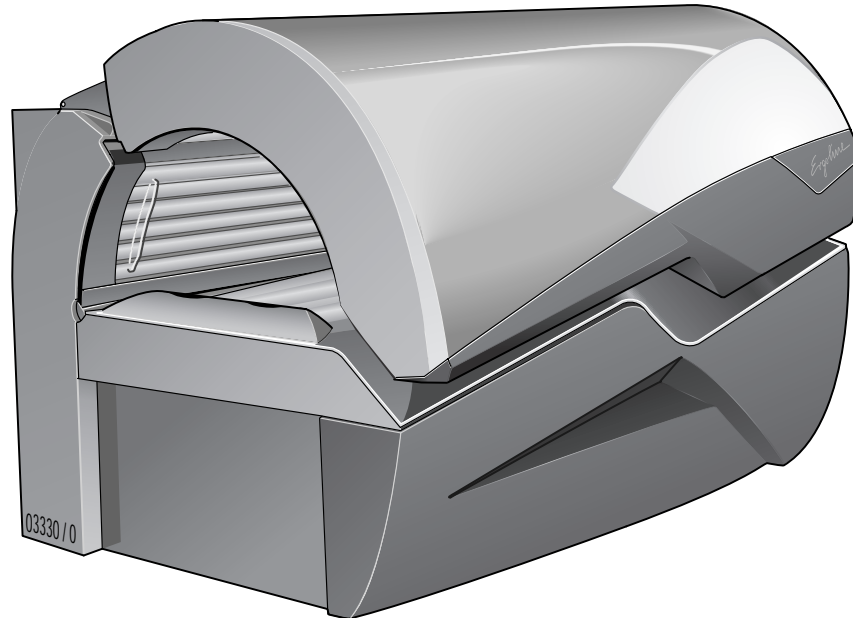

Identify your tanning device

For contact with customer service, please write down the device number of your tanning device.

--	--	--	--	--	--

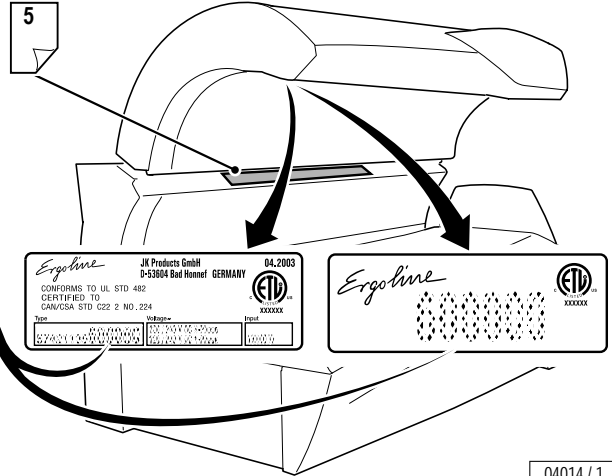
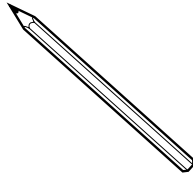

Global Service Division
#1 Walter Kratz Drive
Jonesboro, Arkansas 72401

04014 / 1



(800) 445 0624

DANGER ULTRAVIOLET RADIATION

Follow instructions. Avoid over-exposure as with natural sunlight. Over-exposure can cause eye and skin injury and allergic reactions. Repeated exposure may cause premature aging of the skin and skin cancer.

Maximum Tanning Time is 12 Minutes

Recommended Exposure Schedule

Skin Type	Week 1 1st - 3rd Treatments	Week 2 4th - 6th Treatments	Week 3 7th - 10th Treatments	Week 4 11th - 15th Treatments	Weekly Subsequent Treatments
II - Fair	2 Min.	5 Min.	8 Min.	10 Min.	12 Min.
III - Average	2 Min.	5 Min.	8 Min.	10 Min.	12 Min.
IV - Brown	2 Min.	7 Min.	10 Min.	12 Min.	12 Min.
V - Dark Brown	2 Min.	7 Min.	10 Min.	12 Min.	12 Min.

WEAR PROTECTIVE EYEWEAR! Failure to do so may result in severe burns or long term injury to the eyes.

Certain medications or cosmetics may increase your sensitivity to the ultraviolet radiation. Consult a physician before using sunlamps if you are using medication, have a history of skin problems or believe yourself to be especially sensitive to sunlight. If you do not tan in the sun, you are unlikely to tan from the use of this product.

This unit utilizes UVA lamps. Replace only with **Ergoline VHP 12 160W Turbo Power**, **Ergoline VHP 25W Power (shoulder-/ neck-tanner)** and **JK Ergoline 500 SE C11292 (high-pressure)** or recognized equivalents. To obtain recommended exposure at a minimum distance of 1/2" (13mm) measured with a standard ruler, lie on acrylic surface of lounge and lower canopy. Canopy will stop at the correct distance from lounge acrylic surface.

Warning: The use of any other position may result in overexposure!

Tanning can begin on a regular basis. An appearance of tanning normally appears after a few exposures and maximizes after four (4) weeks of exposure following the recommended exposure schedule for skin type. In order to provide for maintenance of a tan a maximum of two (2) weekly 12 minute sessions is recommended from the fifth week onward.

Use protective eyewear (Part No. Schmeidler 2255 Red or recognized equivalents) when equipment is on. Read and follow instruction booklet before using this product. To avoid electrical shock during maintenance disconnect power from unit.

Part No: 800999



Note:
Description of skin types see Page 20.

04072 / 0

"This product is in conformity with performance standards for sunlamp products under CFR21 Part 1040."

Dear Customer,

The Ergoline device you have purchased is a technically advanced and powerful microcomputer control system. Your device was manufactured with the greatest care and precision. It went through numerous quality and safety checks in order to guarantee trouble-free, safe operation. But you too may make a significant contribution to your long-term satisfaction with your device. Following the tips and instructions in the instruction manual will ensure you enjoyment and pleasure with your device.

In case of any questions, we are always at your disposition¹⁾.

Your sincerely

SUN Ergoline

- Read and observe the information in this instruction manual. This will enable you to prevent accidents and provide you with a reliable device ready for use.
- Always observe the local and federal regulations and legal requirements as well as the valid environmental protection regulations.

1) ☎ (800) 643 0086

Table Of Contents

Intended use	10	Regulating face tanner	27
Danger of damage to persons	10	Switching shoulder tanner off and on	28
Meaning of symbols	13	Regulating Temptronic ¹⁾ (air condition).	29
Guidelines	16	Regulating body cooling	30
Export	16	Regulating facial cooling	31
Equipment	16	Voice Guide	32
Accessories	16	Listening to INFO texts	33
Product information	17	Selecting music channel	34
Maintenance and care	17	Adjusting volume	35
Cleaning	18	Technical Data	36
Environmental protection information	19	Maintenance	Fold-out page, 39
General tanning instructions	19	Maintenance, overview	39
Skin types	20	Maintenance intervals, installed lamps and order numbers	40
Operation	21	Cleaning/replacing UV low-pressure lamps in sunbed base	47
Operating table	Fold-out page, 21	Cleaning/replacing UV low-pressure lamps in neck tanner	49
Overview	21	Cleaning/replacing UV low-pressure lamps in shoulder tanner	51
Accessories	23	Cleaning/replacing UV low-pressure lamps in side section	53
Settings during start-up	25	Cleaning/replacing UV low-pressure lamps in canopy	54
Terminate tanning session	25	Cleaning/replacing interior lighting	56
Running time of accent lights	26		
IR function	26		

1) optional

Cleaning/replacing UV high-pressure lamps/filter panels in side section	58
Cleaning/replacing UV high-pressure lamps/filter panels in canopy	61
Cleaning/replacing accent lights in canopy	64
Cleaning/replacing accent lights in frontpanel	67
Cleaning filters in sunbed base	69
Cleaning/replacing filter mats in canopy	71
Cleaning/replacing filter mats in shoulder tanner	72
Air Condition: cleaning/replacing filter mat, emptying condensate container	74
Presettings	76
Changing presettings with the control panel	76
Changing presettings with a hand-held unit	78
Troubleshooting	81
Index	85
Warranty	87
Timer operation	see separate manual

**Note:**

Technical changes are reserved with respect to the illustrations and specifications in this instruction manual. Reprinting and reproduction, in whole or in part, of this manual is only permitted with our previous written approval and with specification of the source.

Safety notes

Description of warning signs

Danger notes, damage to persons:



Type and source of danger, e.g. "DANGER – High voltage!"

DANGER!

Description of the consequences, e.g. "You can be killed or injured by an electric shock!"

Countermeasures:

- Disconnect device from power supply before opening.
- Do not reach into the inside or change lamps with the device switched on.

Warning notes, damage to persons:



Type and source of danger, e.g. "Warning – hot surface!"

WARNING!

Description of the consequences, e.g. "You can burn your hand (skin, face)!"

Countermeasures:

- Do not touch the lamps and nearby surfaces.
- Wait until lamps and surfaces have cooled down.

Caution notes, property damage:



CAUTION!

The word "CAUTION" with this label points out that danger for devices, materials and the environment can be expected here.

Important information:



Note:

This symbol does not identify safety notes, but states information for a better understanding of the processes.

Intended use

The tanning device is intended exclusively for cosmetic tanning of the human skin:

- This device is used for tanning one adult person at a time.
- The user wears suitable eye protection that blocks UV radiation during tanning.

Any other use shall be considered improper. The manufacturer cannot be held liable for damage or injuries resulting from improper use. The operator bears the sole risk for this.

The proper use also includes compliance with the manufacturer's instructions, operating, maintenance and regulation conditions. The device may only be operated, maintained and repaired by persons familiar with these tasks and that have been informed of the dangers involved.

Important notes for the studio operator

- As the operator you are responsible for informing users on possible risks during tanning.
- All danger and safety labels attached to the device must be observed! Do not remove them!
- No safety equipment (e.g. panel switch) may be removed or deactivated which can impair the safe operation of the device!
- The device may only be operated in proper condition!

Danger of damage to persons



DANGER!

DANGER – High voltage!

You can be killed or injured by an electric shock!

Assembly and electrical connection must comply with the national and local regulations.

– Assembly, installation, upgrading or repair of the device may only be carried out by specially trained and instructed personnel.



WARNING!

Warning – ultraviolet radiation!

Unprotected tanning may result in eye injuries and eye diseases.

The unprotected eye can become inflamed on the surface, and in certain cases the retina can be damaged by excessive radiation. Cataracts can form after frequently repeated exposure to radiation.

– Inform users to close their eyes during tanning and use the included protective goggles that block UV (Order No. 84592¹⁾).

1) Global Service Division – see page 4.

Danger of damage to persons



Warning – ultraviolet radiation!

WARNING! As with natural sunlight, overexposure can cause eye and skin injury and allergic reactions. Repeated exposure may cause premature aging of the skin and skin cancer. Wear protective eye wear; failure to may result in severe burns or long-term injury to eyes.

Occasionally, persons using the tanning device will experience a slight reddening of the skin – usually in small patches – after the second or third session. This redness is often accompanied by an itching sensation. This may be nothing more than a heat “rash” caused by heat from the lamps within the device. It is generally very limited and caused by constant contact of the skin with the acrylic surface. It should go away within approximately 24 hours and should not reappear. This rashing can be lessened or prevented by applying moisturizer lotion to the affected area after the tanning session is completed.

- Follow instructions.
- The time between two tanning sessions must be at least 24 hours!

– Increasing tanning also requires an extension of the exposure time (= radiation time) or after a certain degree of tanning has been achieved, a further intensification is not possible. However, the radiation time may not be extended as desired within the scope of the permissible radiation doses! Therefore, only a certain degree of final tanning dependent on the skin type can be achieved without endangering your health.

– Inform users about proper tanning – see page 19.



Warning – ultraviolet radiation!

WARNING! Danger of long-term consequences.

- Nursing infants and small children through age 7 years may not use this device.
- The following applies to minors under the age of 18 years: Only use tanning devices in agreement with a parent or guardian, or after consulting a physician.
- While there is no immediate clinical evidence of UVA exposure and its effects upon expectant mothers, it is strongly advised that expectant mothers be discouraged from using the tanning unit.







**Warning – risk of infection!**







- WARNING!** Infections can be transferred through skin contact. All items/equipment components, with which the user can come into contact during tanning, must be disinfected after every tanning session.
- Protective goggles
 - Headrest
 - Acrylic sunbed
 - Handles and control panel

Please read and observe ...

Meaning of symbols

Symbols for Description, Operation and Maintenance

General Symbols	
	Inform Customer Service
	Ergoline key
	Do not touch, hot surface!
	Low-pressure lamp(s)
	UV low-pressure lamp(s)
	Starter for low-pressure lamp(s)
	UV high-pressure lamp(s)

General Symbols	
	Accent lamp
	Halogen lamp(s)
	Filter panels
	Cleaning and disinfectant agents
	Part/article number (for orders)
Operation	
	Display of tanning time







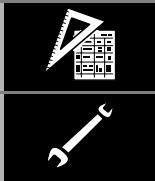

Please read and observe ...

	Display of run-on time (fan run-on)
	Fault display (example)
	Display of Info Track 1
	Display of Music Channel 1 (Channel 1) Factory setting: 1 channel Customer service can set up to 7 channels
	Display when adjusting volume
	Description
	Accent lighting
	Press button
e.g. 2s	Press button for 2 seconds

	Duration: 3 minutes
	Loudspeaker
	Headphone connection
Technical data	
Maintenance	
	Caution, safety switch!
	Unscrew/release screw
	Tighten/lock screw
	Suction cup



Please read and observe ...

	Cleaning
	Replacing
	Clean or replace depending on soiling
	Draining
	Visual inspection
	Air Condition
	Filter/filter mat
...	Continuation of work steps on next page
	End of work step

Presettings	
Troubleshooting	

Meaning of symbols

Guidelines

This device was built according to UL STD 482, certified to CAN/CSA STD C22.2 2 No. 224.



CAUTION – Air inflow and outflow

Do not change, obstruct or block the air inflow and outflow area to the device or make any unauthorized changes to the device. The manufacturer shall bear no liability for damage or injuries resulting from such actions.

Export

We would like to point out that the devices are exclusively intended for use in the US and Canada, and may not be exported to other countries and operated there! The manufacturer shall assume no liability whatsoever in case of non-observance! We explicitly emphasize that high liability risks may occur for the exporter an/or the operator in case of non-observance.

Equipment

The equipment of the devices differs depending on the model.

In this instruction manual all standard and optional components/functions are taken into account which must be observed during operation and/or when performing maintenance.

The control panel is also affected by the differing equipment: Only those buttons are visible that can be operated, i.e. the corresponding function must be part of the equipment of the device.

Accessories

Some accessory parts are taken into account in the maintenance schedule beginning on Page 42, however this does not automatically mean that your device is provided with this equipment (e.g. Temptronic).

An overview of the possible accessories is provided in the sales documentation.

Please read and observe ...

Product information

Acrylic glass panels

The acrylic glass panels for the tanning devices are produced of acrylic glass developed especially for this application. The acrylics used are characterized by a particularly high UV permeability and resistance, as well as an easy-care, hygienic surface that is gentle to the skin.

The acrylic glass panels are formed to their shapes for the specific devices in a technically complex production process. Despite state-of-the-art production know-how, the presence of minor spots, air bubbles or streaks in the acrylic panels is unavoidable. In addition, hairline cracks can occur on the bed surface during operation.

These occurrences are material-dependent and are unavoidable in processing, however have no significant effect on the utility value and can therefore not be recognized as defects.



CAUTION!

Cosmetics or sun screen products must be removed prior to tanning as they can cause damage (e.g. cracks on the surface) when used continuously.

Maintenance and care



DANGER!

Extreme danger! High voltage!

During maintenance work there is a danger of touching live parts and receiving a fatal electrical shock.

- Disconnect device from power supply before opening – also see Page 39.
- Do not reach behind covers, do not open the device and do not replace lamps with the device switched on.

Maintenance and care play a major role in deciding whether the device meets the requirements placed on it in a satisfactory manner. The compliance with the specified maintenance intervals and the careful conducting of the maintenance and care work are therefore absolutely necessary – see Page 42 ff.

The current operating hours of the parts requiring maintenance can be displayed in the Presetting mode – see Page 76 ff.

Remount any protective devices (e.g. filter panels) after completing work.



CAUTION!

Only use original spare parts of the same type or compatible parts! The use of other parts voids the conformity! Any liability is excluded in case of damage or injury proven to be the result of the use of non-original spare parts.

Cleaning

Acrylic glass surfaces

**CAUTION!**

Do not rub with a dry cloth – danger of scratching!
For fast, hygienic proper cleaning of acrylic glass surfaces, use exclusively the specially developed fast disinfectant cleaner Antifect®.

Other cleaning agents, especially concentrated disinfectants or solvents (e.g. Lysoform, ethyl alcohol or other liquids containing alcohol), may not be used for cleaning.

Failure to observe this voids all warranty claims.

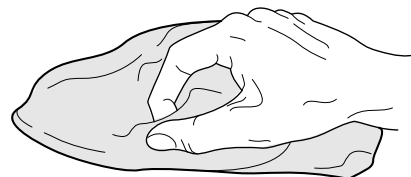
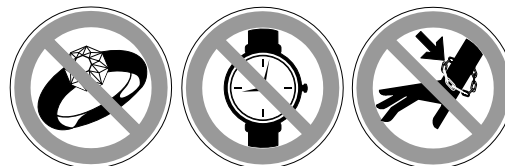

02756 / 0

Plastic surfaces

For cleaning the other plastic surfaces, it is best to use warm water and a leather cloth. Never use aggressive cleaning agents containing alcohol, e.g. the commercially available Sagrotan, or essential oils. These may lead, in the long run, to damages not covered by the warranty.

During cleaning a slight discoloration of the leather cloth by the rubber seals must be expected for production-related reasons.

**Note:**

Prevent damage to the acrylic glass and plastic surfaces. Remove rings, watches, bracelets etc. before the start of cleaning work.

Please read and observe ...

Environmental protection information

Environmental Declaration – The JK Corporate Group

The JK corporate group is subject to the strict regulations of EC Directive 761/2001 and the standard DIN ISO 14001, and undergoes regular internal and external environment audits performed by trained auditors.

Environmental regulations – disposal of lamps

UV low-pressure lamps and UV high-pressure lamps contain fluorescent materials and other waste containing mercury.

According to the national waste disposal laws and in accordance with the municipal waste regulations, proof must be provided of the proper disposal of UV lamps.

Your local environmental agency will be happy to assist you with the disposal of UV lamps.

General tanning instructions

Who can get a tan?

Anyone who also gets a tan in natural sunlight. Persons with sensitive skin even tan more pleasantly and with fewer worries, as the radiation dosage can be exactly defined with sunbeds.

Certain drugs – particularly those that produce photosensitivity – may cause individuals under the influence of this type drug to experience adverse effects and those people should avoid exposure to UV sources of all kinds. Doctors will advise people taking these drugs to possible adverse effects.

The speed and intensity with which someone tans are dependent on the skin type and the individual melanin quantity in the skin. No two individual skin tones are the same. A tan to one person may be different to another and treatment length may vary.

What is Melanin?

The brownish pigment produced by special cells in the base layer of your skin determines the individual's tan. As the skin is exposed to the ultraviolet light, the melanin is activated and combines with protein cells that rise to the skin's surface, thus producing a tan. The amount of melanin in your body determines how quickly and dark you tan. The more melanin produced and exposure time an individual has, the faster and deeper the individual will tan.

Please read and observe ...**Note:**

The tan produced by the tanning unit is a deep, rich "Cosmetic" tan. However, regardless of how dark an individual may tan on his system, it will not provide adequate protection against overexposure to natural sunlight or UVB tanning systems.

Which tanning times are recommended?

Although there is virtually no reason to worry about sunburn with the UV tanning method, some consideration should initially be given to individual skin sensitivity.

**Danger of skin injuries and skin diseases!**

DANGER! Although UVA radiation is relatively harmless compared to natural sunlight, excessive tanning times can lead to the skin becoming red and to burns.

- Comply with the recommended tanning times, see Page 5.

Once you have a tan, 1 to 2 tanning sessions per week are usually sufficient to maintain it.

Should you use sun screen?

No! It is recommended to not use sun screens, oils or lotions intended for outdoor use. Cosmetic sun screens with a sun protection factor (SPF) are intended to filter out the sun's aggressive rays. However, the light of

our sunbeds only contains extremely small quantities of comparable rays, making this kind of protection unnecessary. On the contrary, the skin should be thoroughly cleaned and dried before each sunbath. Many facial makeups have oil bases and should be removed prior to a session.

Adequate ventilation of the room or booth housing the tanning device is required for proper and comfortable operation. Your tanning device will perform best at the ambient temperature of 75 °F to 90 °F.

It is recommended that, following a tanning session, a skin moisturizer be applied. This promotes a smoother, more even looking tan.

Skin types

For the recommended exposure schedule (see page 5):

Skin type II:

This is the individual that usually burns easily and severely, tans minimally or lightly and peels.

Skin type III:

Often referred to as "Average" complexion, burns moderately and tans about average.

Skin type IV:

This individual burns minimally, tans easily and above average with each exposure.

Skin type V:

This individual's system rarely burns, tans easily and substantially.

Operation

Mandatory reading

Always read and follow all instructions for proper usage prior to using any tanning device. The operating instructions included with this device must always be followed to prevent possible injuries or to reduce them to a minimum.

Inform users

- to use provided UV-blocking protective eyewear whenever the equipment is energized.
- to follow the exposure schedule in accordance with their skin type. Failure to do so may result in overexposure.

A tanning system is not a toy. You cannot vary the strength of the lamps in your unit.

Should you have any questions regarding the proper use of your tanning system, contact SUN Ergoline at:

☎ 1-800-643-0086

8:00 a.m. to 5:00 p.m. (CST)



WARNING – ultraviolet radiation!

WARNING! Danger of skin injuries and skin diseases!
 – The sunbed may never be used when a filter panel is missing or damaged, or the timer is defective!



Note:

When describing the operation, the tanning device is often shown with the canopy open. During tanning the canopy must always be closed.

No proper operation is possible with the canopy open.

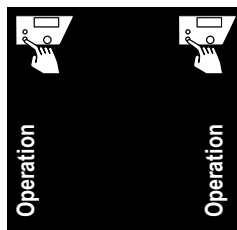

Please open this fold-out page.

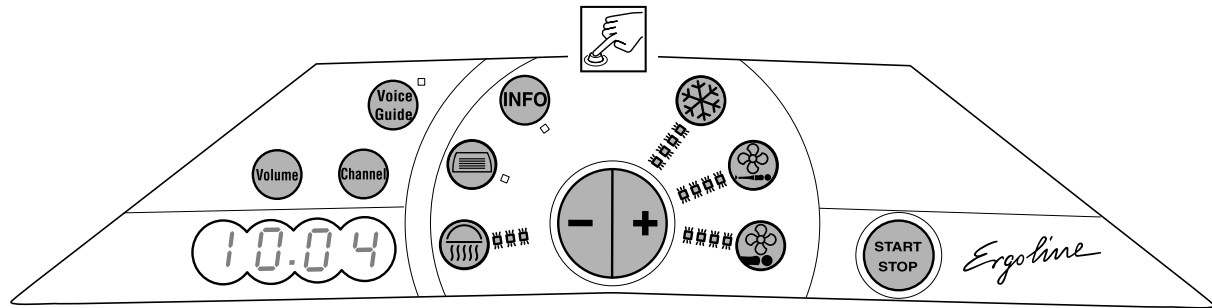

04906 / 0

USA

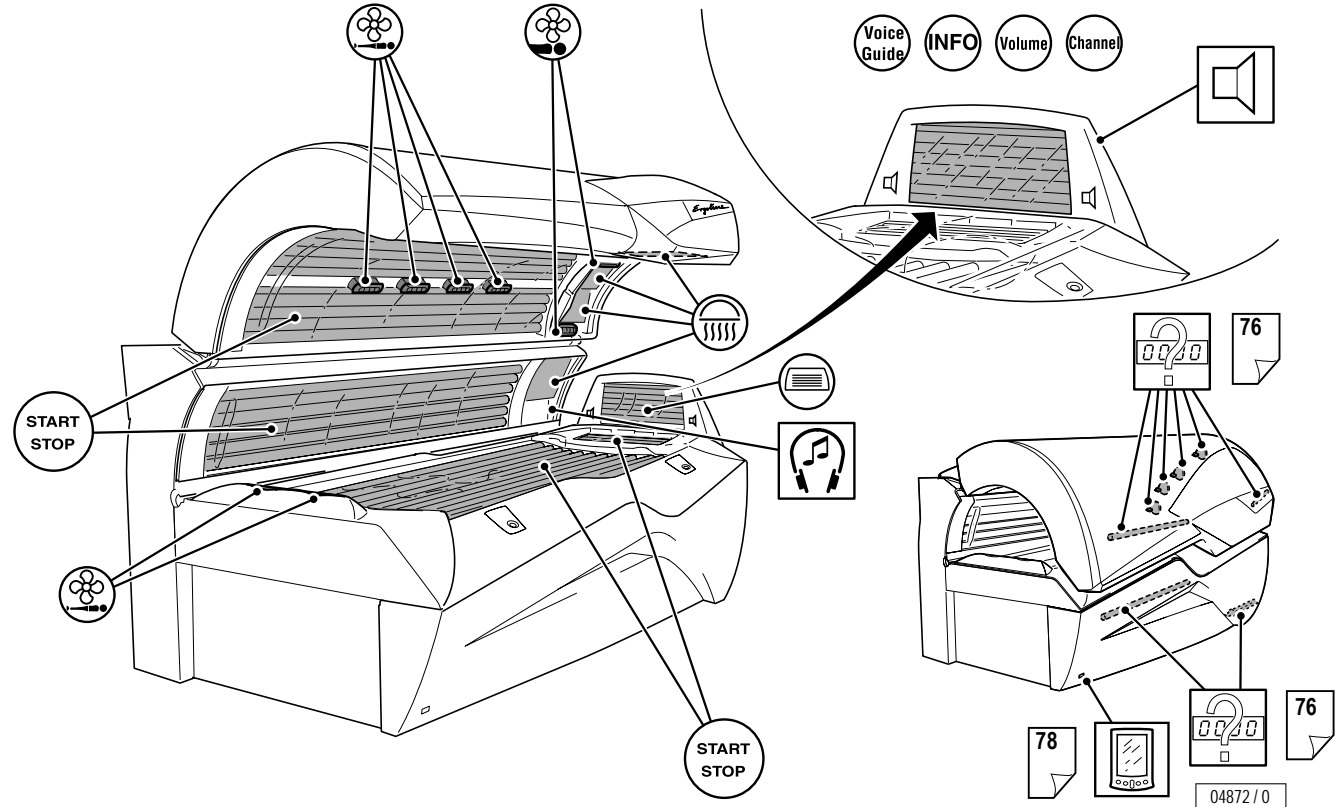
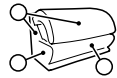

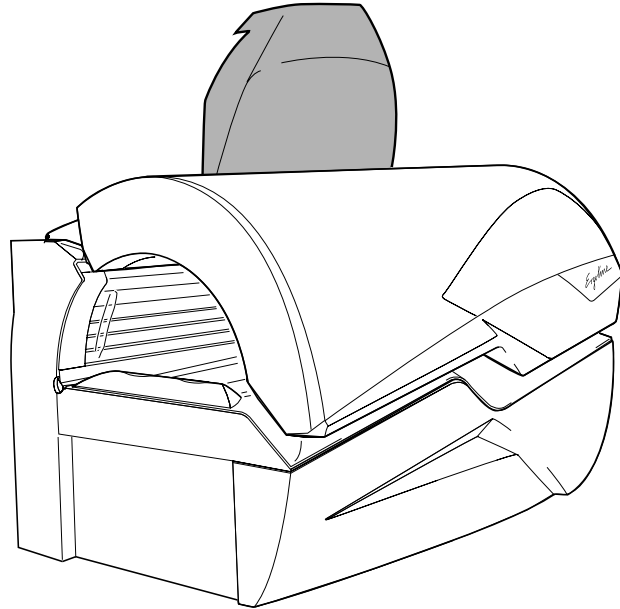
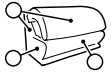

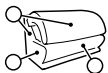

Tanning

Start and end of tanning

The device is started automatically with an internal or external timer and automatically stopped after the preselected time. The fan continues to run for approx. 3 minutes (fan delay) to sufficiently cool the device.



Note:
Timer instructions: see separate manual.

Preparation time

Before the UV lamps automatically go on, you have a few minutes to prepare yourself. During the preparation time you can switch on the UV lamps at any time by pressing the START/STOP button.

- Remove your clothes and all jewelry.
- Remove make-up and other cosmetics.
- Remove glasses. Contact lenses can be worn under the protective goggles.
- Put on the protective goggles.
- Lie down on the bed surface.
- Close the canopy.

Depending on the controller, the tanning device starts up after a short time automatically. The tanning device is operating when the UV lamps are on and the fans are running.

If the device fails to start up when you have closed the canopy:

- Press START/STOP to start tanning.

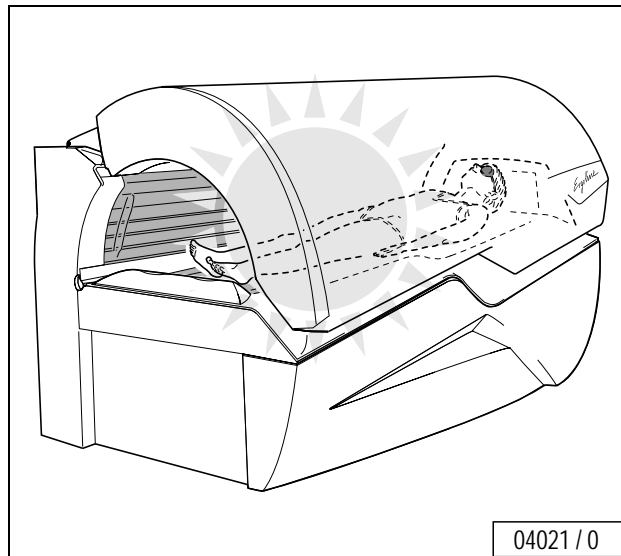

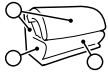

Settings during start-up

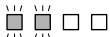
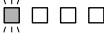
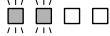
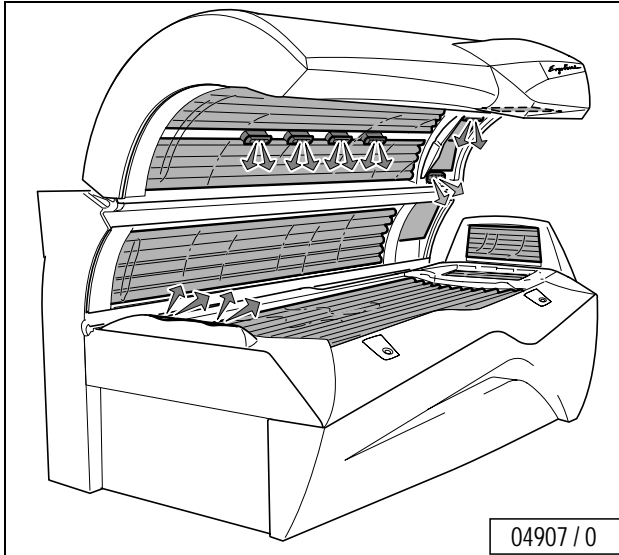

To interrupt tanning session

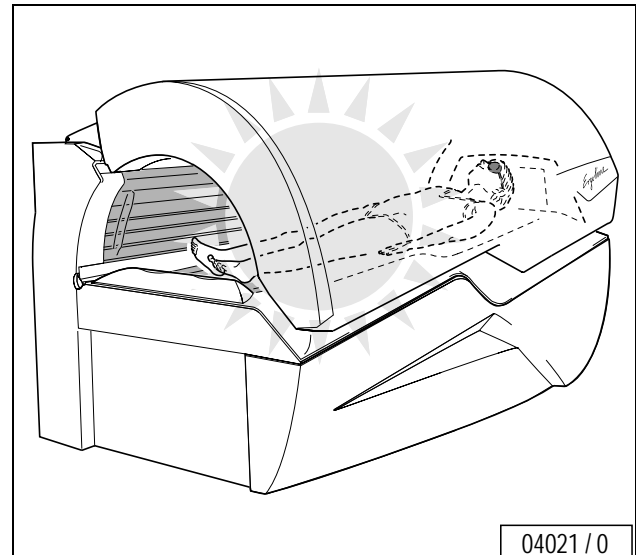

The tanning time can be interrupted during tanning by switching off the UV lamps:

- Press START/STOP for three (3) seconds to pause or stop tanning.
- Press START/STOP again for three (3) seconds to restart the lamps.



Operation





Running time of accent lights

Operation

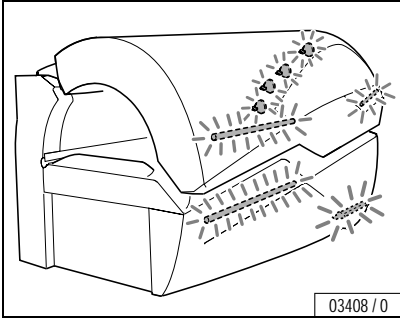

03408 / 0

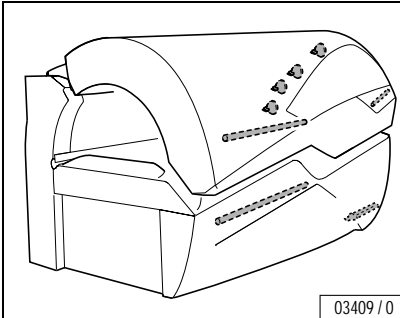
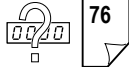

03409 / 0

The accent lights are running during and after the tanning session and are automatically switched off at the end of the predefined time. The running time of the accent lights in the Standby mode can be changed with the presettings – see from Page 76 on.

IR function

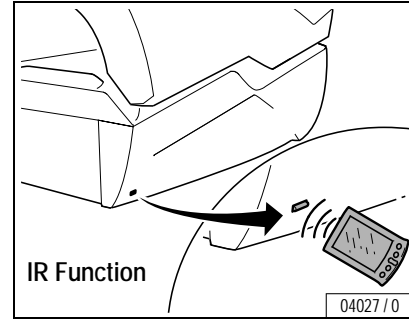
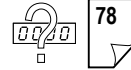

IR Function

04027 / 0





Face tanner

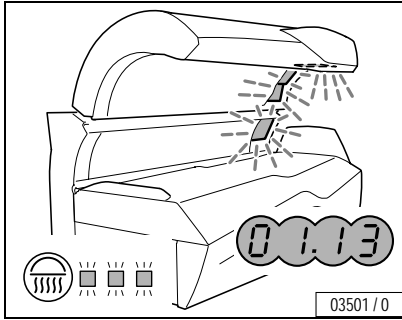

03501 / 0

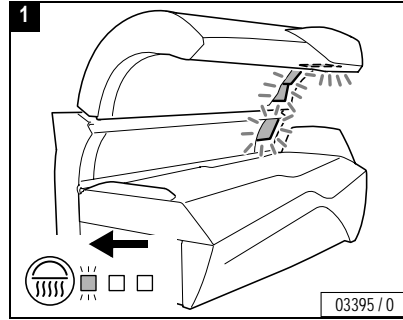

03395 / 0

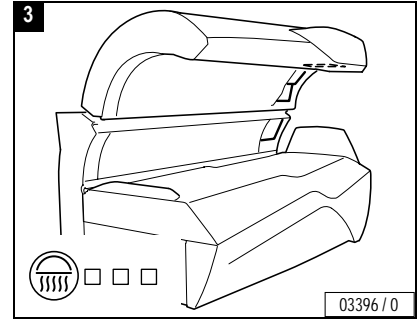

03396 / 0

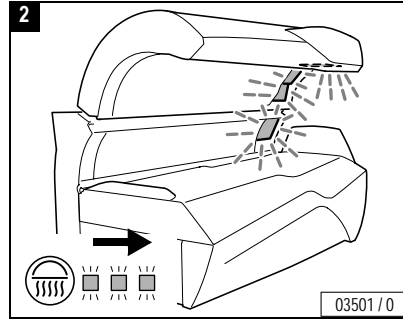

03501 / 0

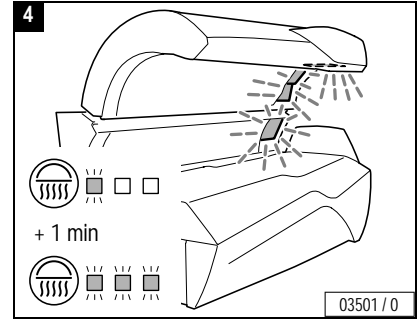
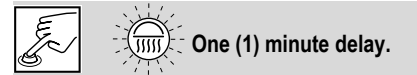

03501 / 0



Operation

Switching the face tanner OFF:

– Press button  for two (2) seconds.

Switching on face tanner again:

– Press button  again. It takes approx. one (1) minute until the face tanners reach their full output.





Shoulder tanner

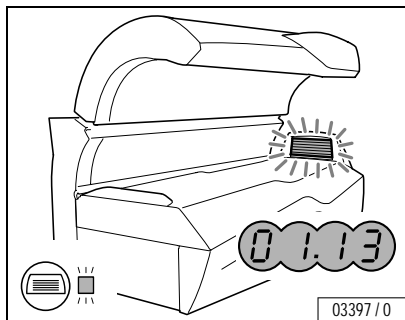

Press for two (2) seconds.

1

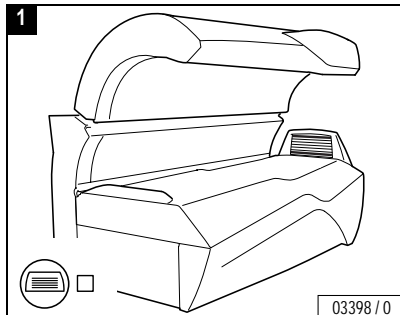

2

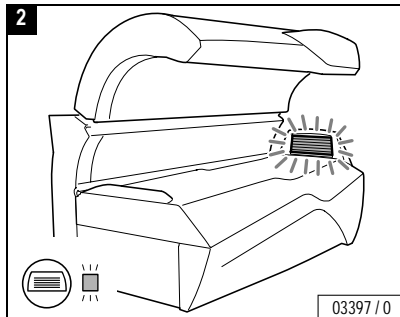

Switching the shoulder tanner OFF:

- Press button  for two (2) seconds.

Switching the shoulder tanner on again:

- Press button  again.





Temptronic – Adjust coolness

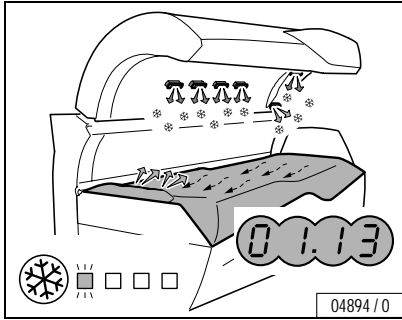

- During start-up the second of 8 levels is active
- Press button  (Temptronic).
 - While the button flashes, press the plus or minus button to change the cooling intensity.

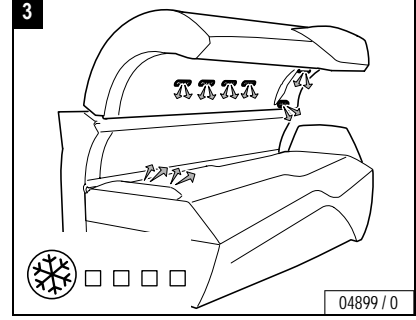
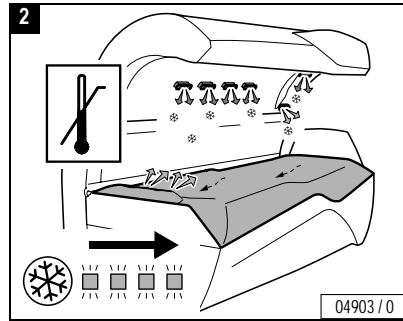
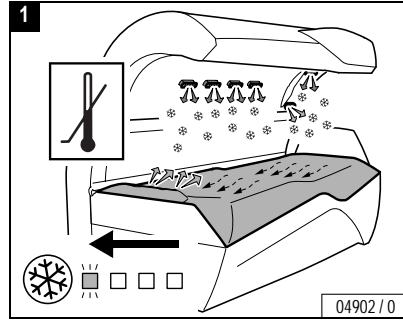



Surround cooling body nozzles – Adjust speed



Operation

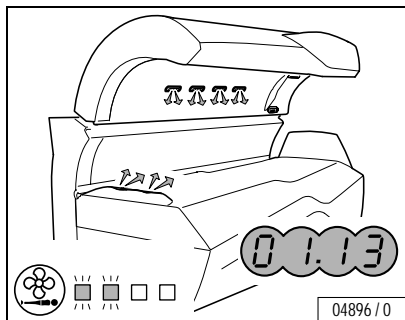

04896 / 0

– Press button .

– While the button flashes, press the plus or minus button to change the intensity of the air stream.

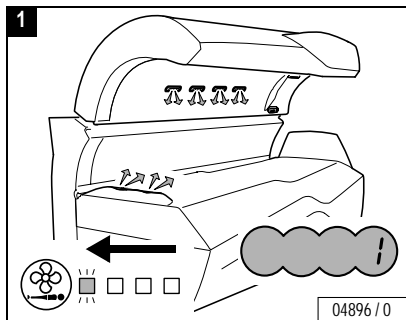

04896 / 0

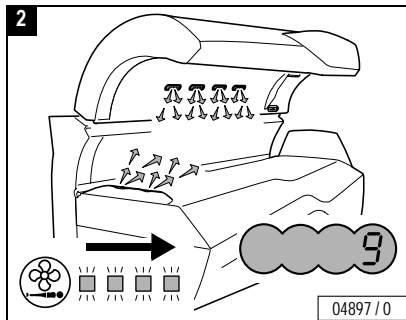



04897 / 0



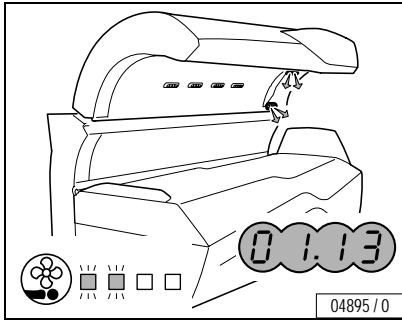

Surround cooling head nozzles – Adjust speed



- Press button .
- While the button flashes, press the plus or minus button to change the intensity of the air stream.

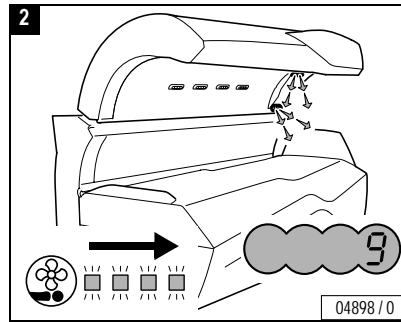
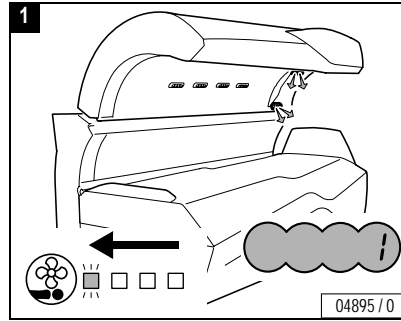

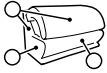

Voice Guide

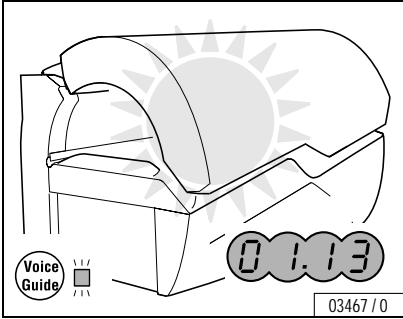

When Voice Guide is switched on, you hear an explanation of the button function each time a button is pressed.

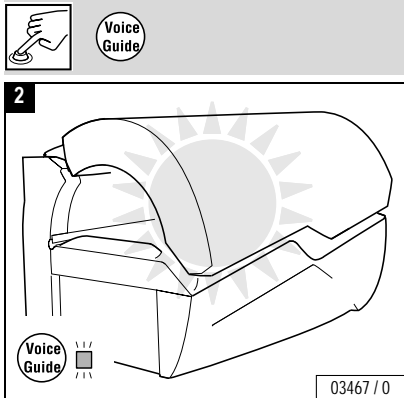
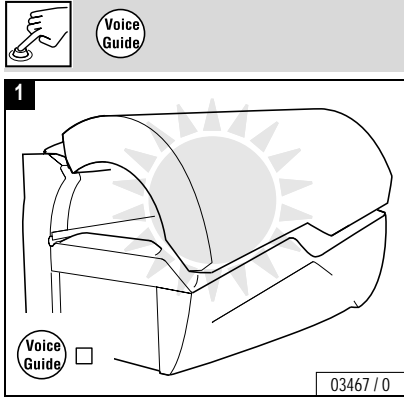

- ...
- ...
- ...
- ...
- ...
- ...
- ...
- ...
- ...



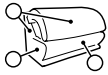

INFO



USA

INFO

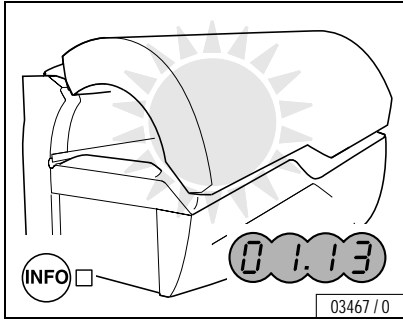

When you press the **INFO** button, general texts on tanning are played.

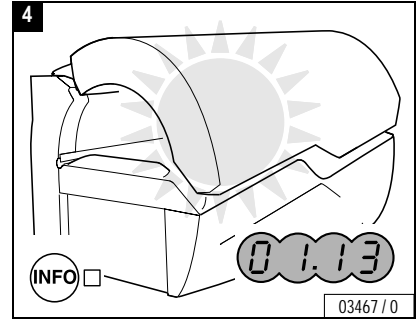
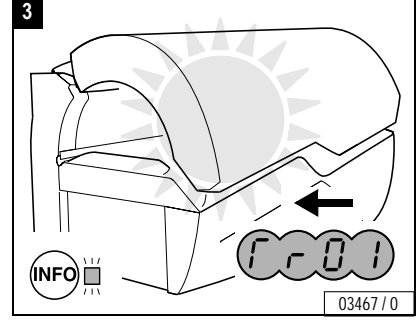
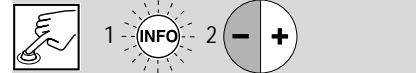
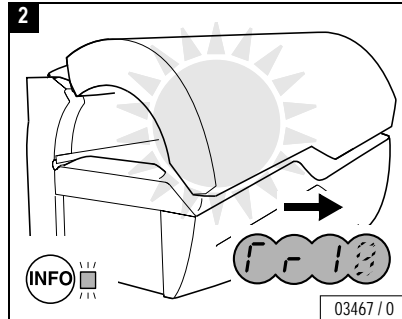
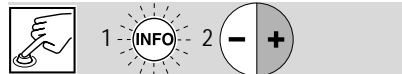
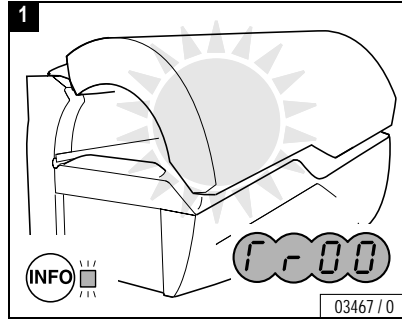
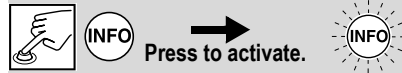

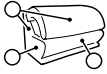

Channel

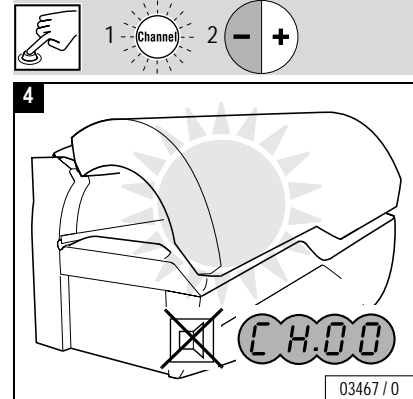
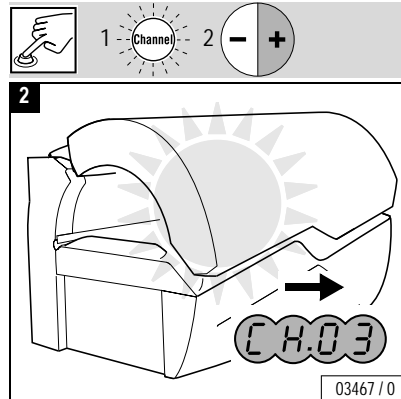
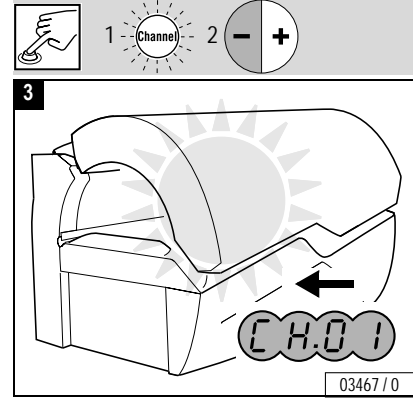
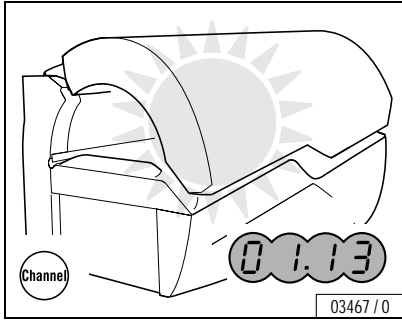

– Press button .

– While the button flashes, press the plus or minus button to select a channel.

CH.00 means: no Channel selected, there is no sound, music is "OFF".



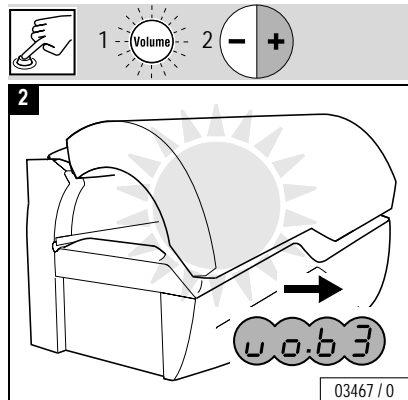
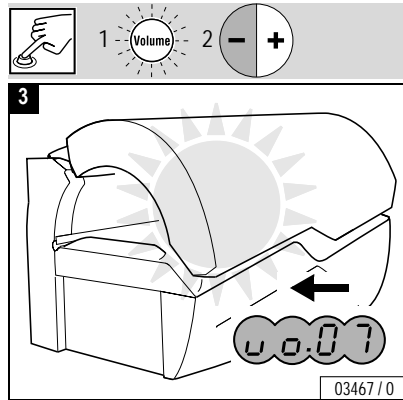
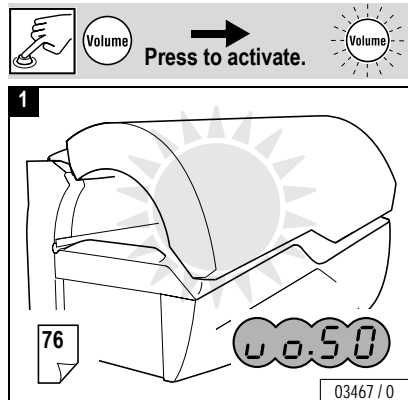
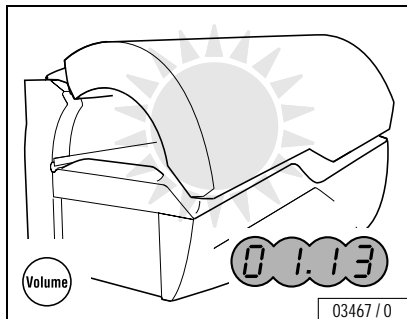

Volume



- Press button .
- While the button flashes, press the plus or minus button to change the volume.





Model:	Ergoline Excellence 800 Turbo Power
Rated power consumption:	13,900 W 17,000 W 
Rated voltage:	230 V
Rated frequency:	60 Hz
Rated fusing:	50 amp 3-pole 80 amp 2-pole
Conformity mark:	

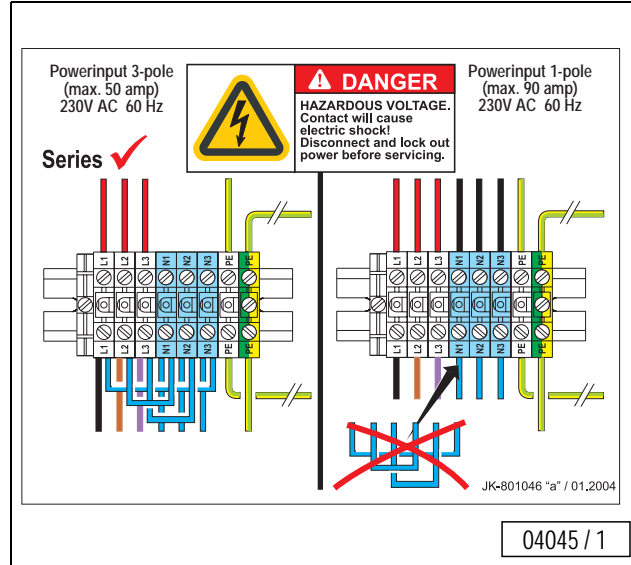



Bed tolerance in room

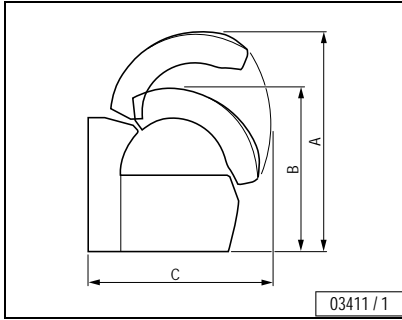

03411 / 1

A = 1830 mm	A = 72 1/16 in
B = 1373 mm	B = 54 1/16 in
C = 1510 mm	C = 59 7/16 in
D = 2110 mm	D = 83 1/16 in
E = 2323 mm	E = 91 7/16 in
F = 850 mm	F = 33 7/16 in

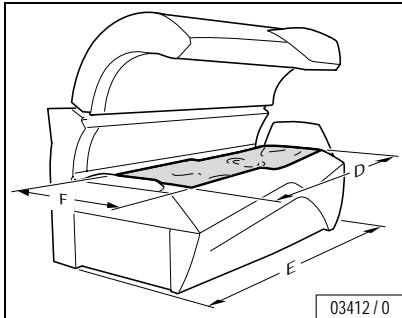

03412 / 0

Maximum room temperature / Humidity

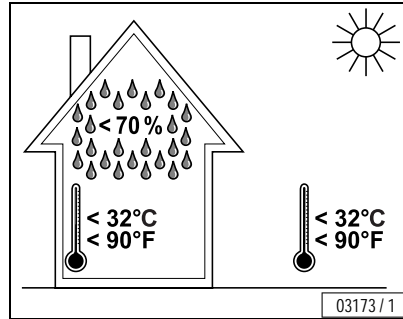

03173 / 1

Maximum permissible load

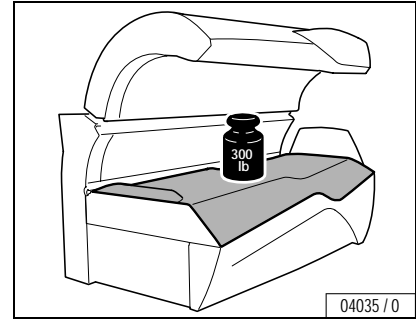

04035 / 0



WARNING!

Warning – possible breakage of the acrylic panel!

Severe cuts from glass and burns from hot lamps may result.

- Only one adult person is allowed at the same time.
- People that weigh more than 300 lbs must not use the device at all.







USA

USA



Maintenance

De-energize device and secure against being switched on again



DANGER!

Extreme danger!

If work is to be performed on the devices, they must be de-energized. That means that all live lines must be switched off.

Switching off the device alone is insufficient, as certain points may remain energized. Therefore, switch off fuses before performing any work and – if possible – remove them.



04049 / 0

- In case of circuit breakers which cannot be screwed out, a strip of adhesive tape may be applied over the actuation lever with the wording "Do not switch, danger!".

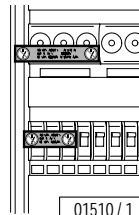

01510 / 1

A prohibition sign with the text:

- "Work in progress!"
- "Place:"
- "Sign may only be removed by:"

must always be securely mounted immediately.



01511 / 1

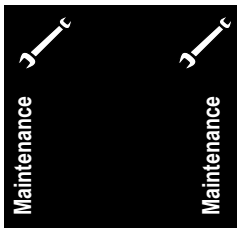

Please open this fold-out page.



DANGER!

Extreme danger!

Severe accidents can occur if the device is mistakenly switched on again.

Immediately after de-energizing, secure all switches or fuses used for de-energizing against being switched on again.



DANGER!

Extreme danger!

Prohibition signs must not be hung on or touch live parts.

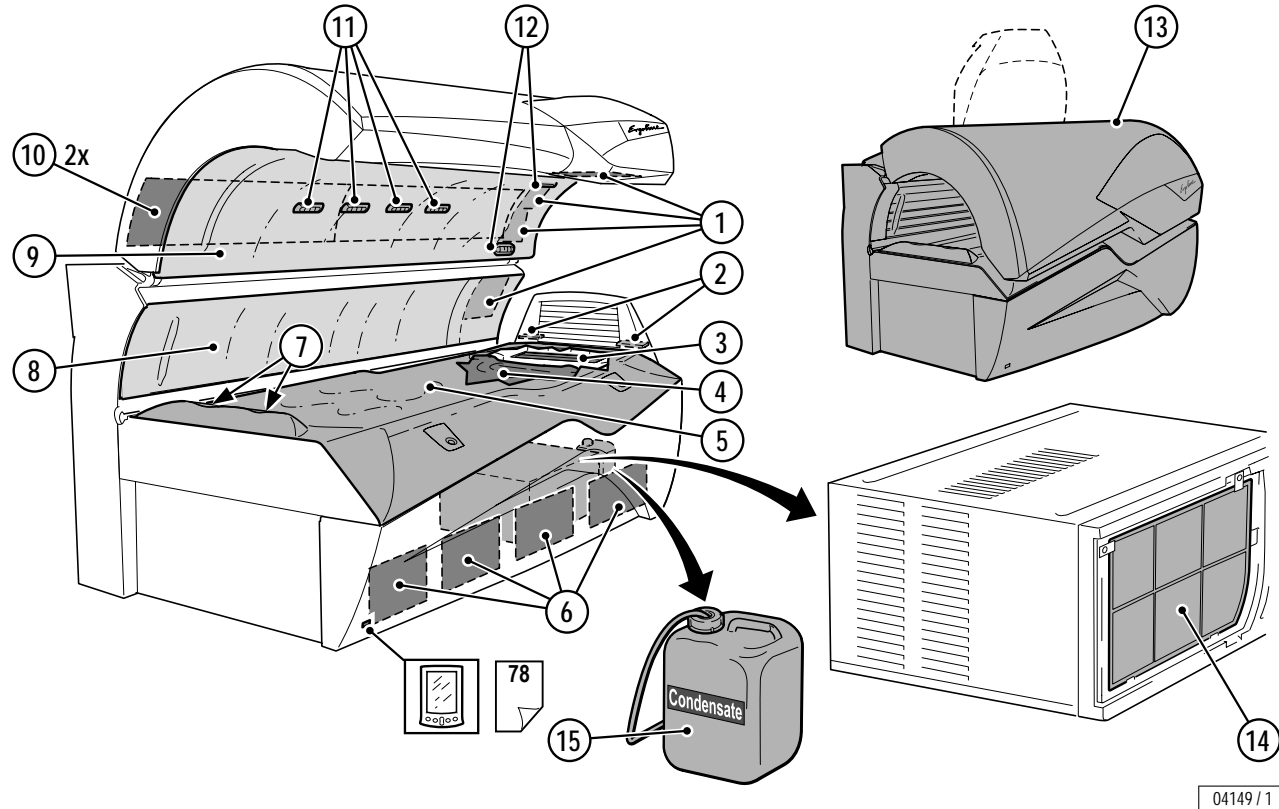
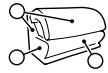

04149 / 1

USA



Scheduled cleaning

	⑤	<p>Note: Clean after every use.</p>	



Warning – risk of infection!

Protective goggles may only be cleaned with an approved disinfectant.



Scheduled cleaning



 Clean if necessary!	① - ⑬ 	⑮ 	
	⑬ 		
	④ 		





Scheduled maintenance – filters

/50 h	⑥ 4 x		51 937		69
	⑩ 2 x		800 601		71
	⑭ 1 x		51 975		74
	② 2 x		800 278		72



Scheduled maintenance – accent lights











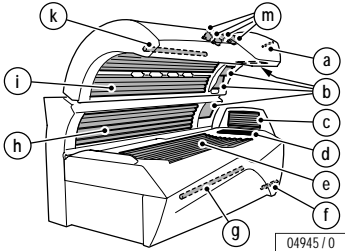

	Excellence 800 Turbo Power VHP 12																																																																																														
	 <small>03468 / 1</small>	<table border="0"> <tr> <td>a)</td> <td>1 x</td> <td></td> <td>white</td> <td>8 W</td> </tr> <tr> <td>f)</td> <td>1 x</td> <td></td> <td>blue</td> <td>9 W</td> </tr> <tr> <td></td> <td>1 x</td> <td></td> <td>red</td> <td></td> </tr> <tr> <td>g)</td> <td>1 x</td> <td></td> <td>blue</td> <td>30 W</td> </tr> <tr> <td></td> <td>1 x</td> <td></td> <td>red</td> <td></td> </tr> <tr> <td>k)</td> <td>1 x</td> <td></td> <td>blue</td> <td>30 W</td> </tr> <tr> <td>m)</td> <td>4 x</td> <td></td> <td></td> <td>12 V</td> </tr> <tr> <td></td> <td>1 x</td> <td></td> <td>red</td> <td></td> </tr> <tr> <td></td> <td>1 x</td> <td></td> <td>yellow</td> <td></td> </tr> <tr> <td></td> <td>1 x</td> <td></td> <td>blue</td> <td></td> </tr> <tr> <td></td> <td>1 x</td> <td></td> <td>pink</td> <td></td> </tr> <tr> <td></td> <td>1 x</td> <td></td> <td>orange</td> <td></td> </tr> <tr> <td>a) g) k)</td> <td>3 x</td> <td></td> <td>S10</td> <td></td> </tr> </table>	a)	1 x		white	8 W	f)	1 x		blue	9 W		1 x		red		g)	1 x		blue	30 W		1 x		red		k)	1 x		blue	30 W	m)	4 x			12 V		1 x		red			1 x		yellow			1 x		blue			1 x		pink			1 x		orange		a) g) k)	3 x		S10			<table border="0"> <tr><td>11839</td><td>64</td></tr> <tr><td>12262</td><td>67</td></tr> <tr><td>12458</td><td></td></tr> <tr><td>12377</td><td>67</td></tr> <tr><td>12459</td><td></td></tr> <tr><td>12263</td><td>56</td></tr> <tr><td></td><td>64</td></tr> <tr><td>701830</td><td></td></tr> <tr><td>701826</td><td></td></tr> <tr><td>701827</td><td></td></tr> <tr><td>701829</td><td></td></tr> <tr><td>701831</td><td></td></tr> <tr><td>10047</td><td></td></tr> </table>	11839	64	12262	67	12458		12377	67	12459		12263	56		64	701830		701826		701827		701829		701831		10047	
a)	1 x		white	8 W																																																																																											
f)	1 x		blue	9 W																																																																																											
	1 x		red																																																																																												
g)	1 x		blue	30 W																																																																																											
	1 x		red																																																																																												
k)	1 x		blue	30 W																																																																																											
m)	4 x			12 V																																																																																											
	1 x		red																																																																																												
	1 x		yellow																																																																																												
	1 x		blue																																																																																												
	1 x		pink																																																																																												
	1 x		orange																																																																																												
a) g) k)	3 x		S10																																																																																												
11839	64																																																																																														
12262	67																																																																																														
12458																																																																																															
12377	67																																																																																														
12459																																																																																															
12263	56																																																																																														
	64																																																																																														
701830																																																																																															
701826																																																																																															
701827																																																																																															
701829																																																																																															
701831																																																																																															
10047																																																																																															





Scheduled maintenance – UV lamps, starters

	Excellence 800 Turbo Power VHP 12			
500 h				
	a) f) g) k) m)			43
	b) 4 x  JK Ergoline 500 SE C11292 500 W		11292	58, 61
	e) 19 x  Ergoline VHP 12 160W Turbo Power		12557	47
	h) 8 x  Ergoline VHP 12 160W Turbo Power		12557	53
	i) 24 x  Ergoline VHP 12 160W Turbo Power		12557	54
	d) 6 x  Ergoline VHP 25W Power		12562	49
	c) 7 x  Ergoline VHP 25W Power		12562	51
1,000 h	e) h) i) 51 x  S12		10012	
	c) d) 13 x  S10		10047	



The UV high-pressure lamps used, JK Ergoline 500 SE C11292 (face tanner), are broadband radiators that can be operated with different wattages (approx. 240-520 W).



UV low-pressure lamps: Clean with plain water (damp cloth).



1,500 h	⑤			700624	47
3,000 h	④			800399	47
	③			800389	49
	①	(ViT)		704288	58, 61



Filter panels: Clean with plain water (damp cloth).



Relamping / maintenance instructions

It is imperative that you, the owner and/or operator, check all components for any signs of wear which may occur through normal use.

- Observe the cleaning and maintenance schedule specified in the maintenance table on Page 40 to 45.
- Only replace UV low-pressure lamps with the original lamp type or with compatible lamps.
- Only replace UV high-pressure lamps with the original lamp type or with compatible lamps.

Should you require any assistance or need additional information, please call Global Service Division at 1-800-445-0624, Monday through Friday 8:00 a.m. - 7:00 p.m. (CST).



CAUTION – Damage due to improper maintenance!

Improper maintenance can cause the device to be damaged or to become unusable.

- Always comply with the specified maintenance intervals.
- Follow the cleaning instructions.
- If the maintenance intervals for the UV lamps are exceeded or incompatible UV lamps are installed, the share of harmful UVB radiation may increase. Sunburn and other skin damage may result.



Danger of burns from hot lamps and device parts

WARNING! If the tanning device was operated before being switched off and opened, lamps and housing parts may be hot.

- Before replacing lamps or other spare parts, wait until lamps and metal parts of the device have cooled down sufficiently.



Danger of pinching!

When opening and closing the tray, panels and covers, you can pinch your fingers.

- Avoid hinges.





UV low-pressure lamps, lower section

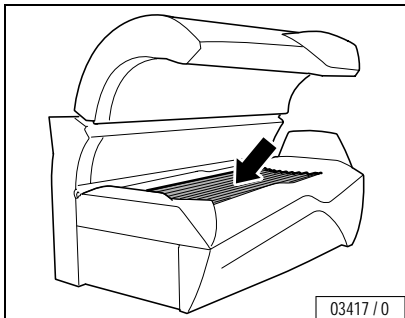
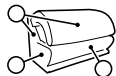

03417 / 0

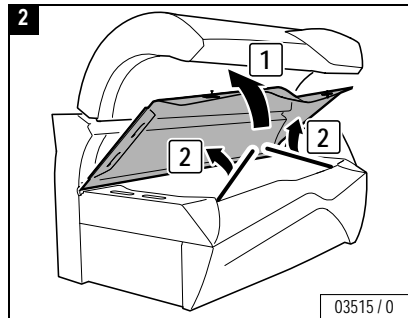

03515 / 0

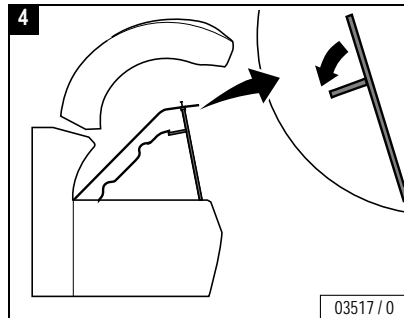

03517 / 0



De-energize device!

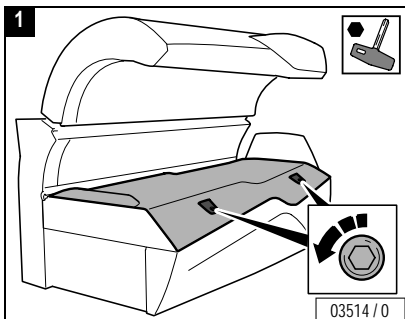

03514 / 0

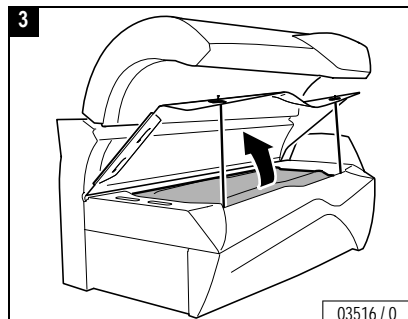

03516 / 0

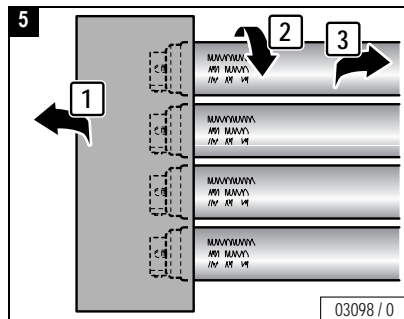

03098 / 0



Maintenance



Maintenance

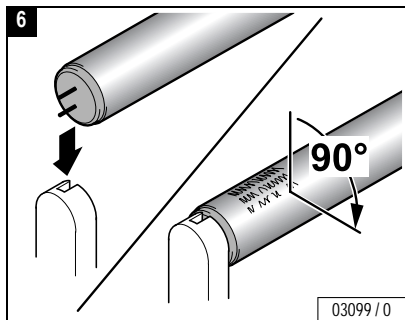

Close:

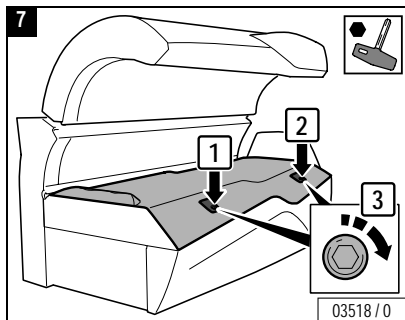



UV low-pressure lamps, neck tanner

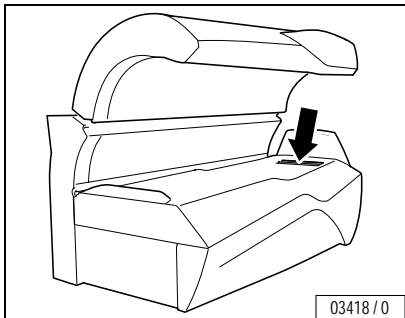
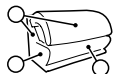

03418 / 0

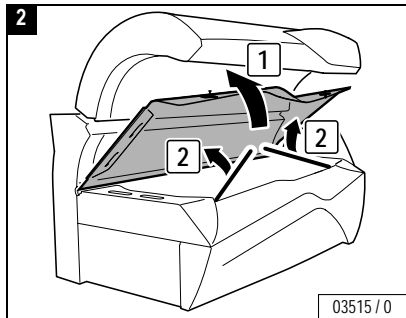

03515 / 0

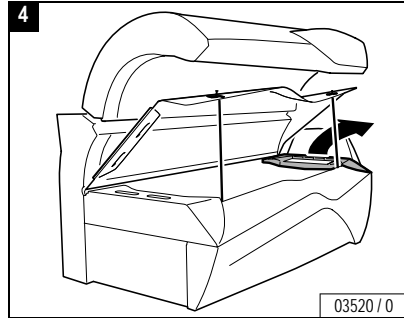

03520 / 0



De-energize device!

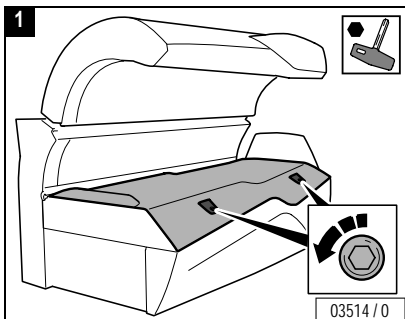

03514 / 0

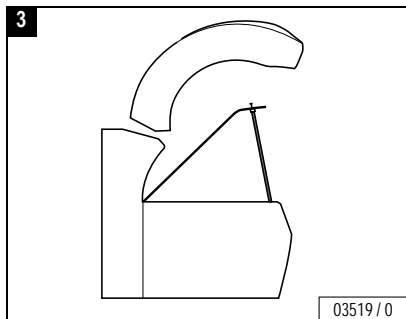

03519 / 0

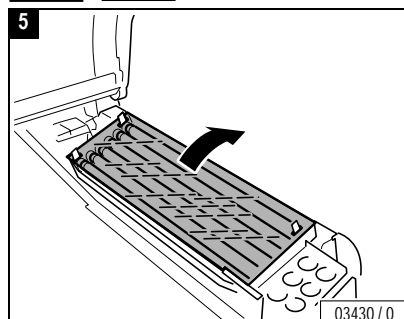

03430 / 0



Maintenance

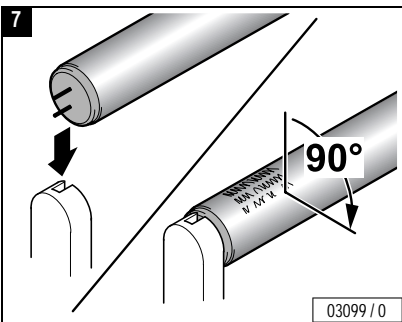
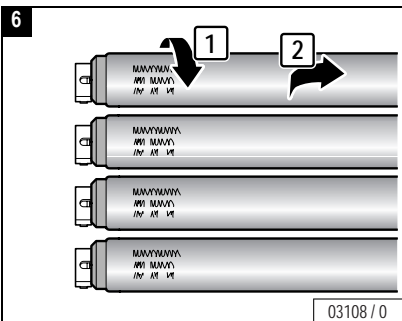

Close:

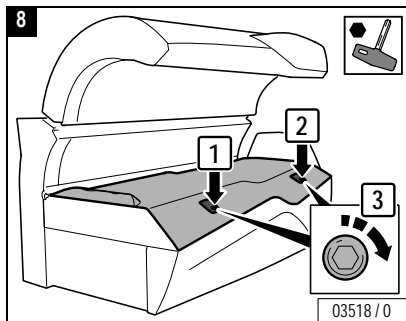

Maintenance





UV low-pressure lamps, shoulder tanner

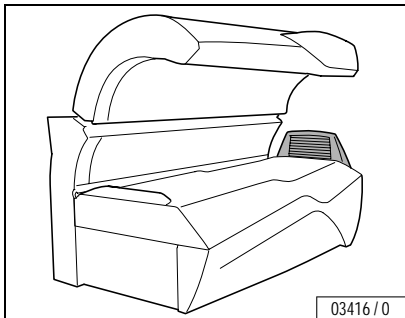
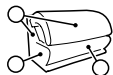

03416 / 0

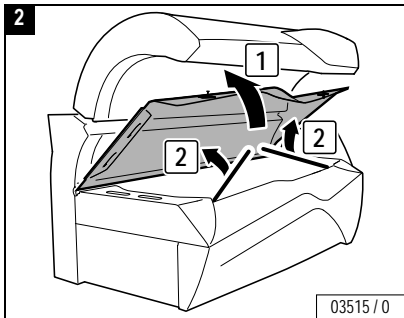

03515 / 0

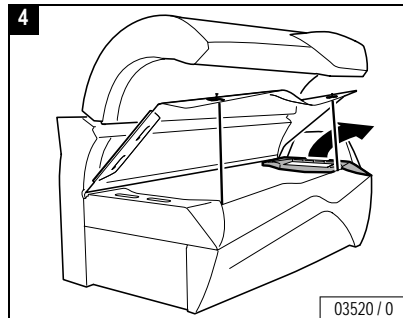

03520 / 0



De-energize device!

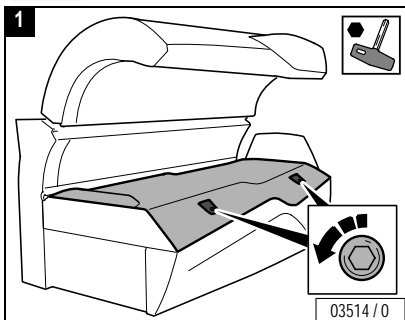

03514 / 0

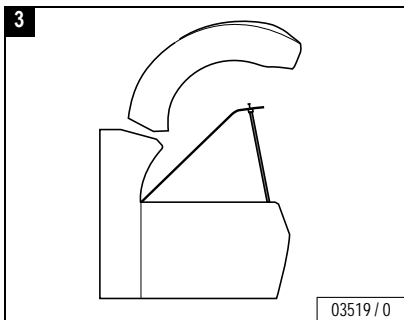

03519 / 0

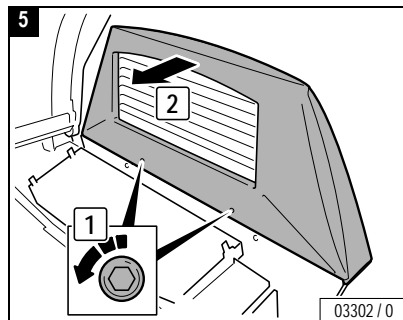

03302 / 0



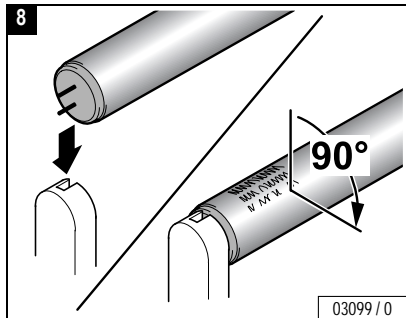
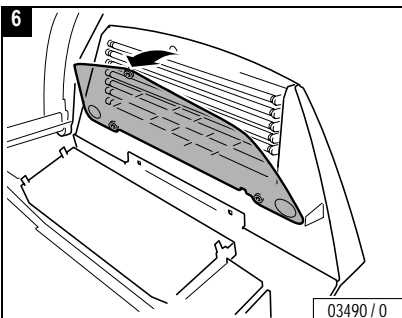

Close:

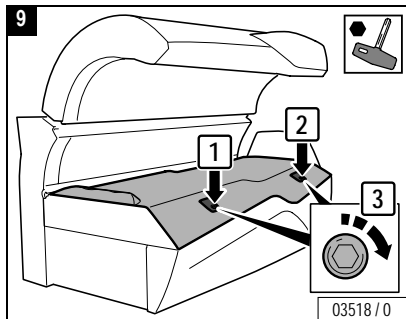
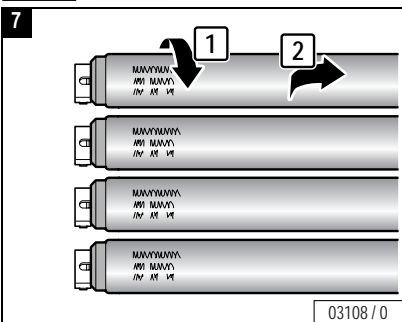

Maintenance





UV low-pressure lamps, side section

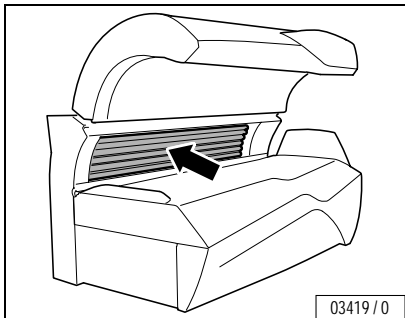
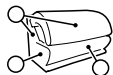

03419 / 0

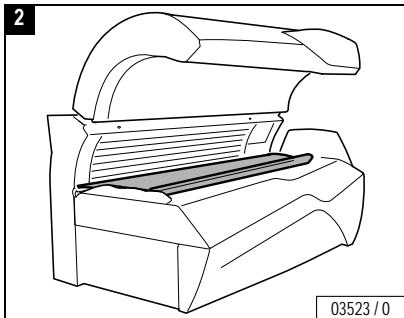

03523 / 0

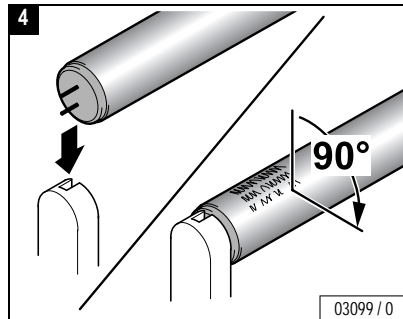

03099 / 0



De-energize device!

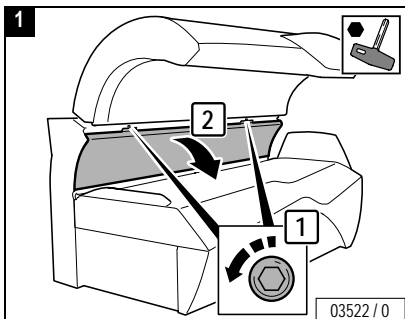

03522 / 0

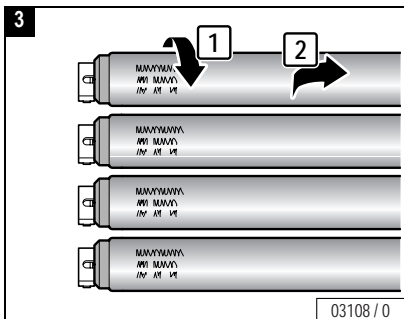

03108 / 0

Close:

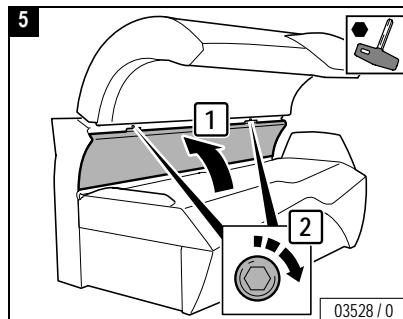

03528 / 0

Maintenance



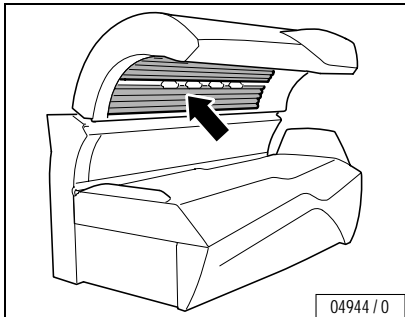
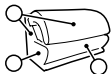

De-energize device!

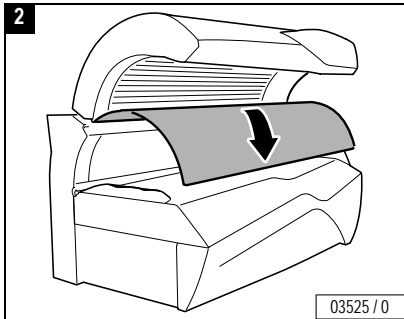
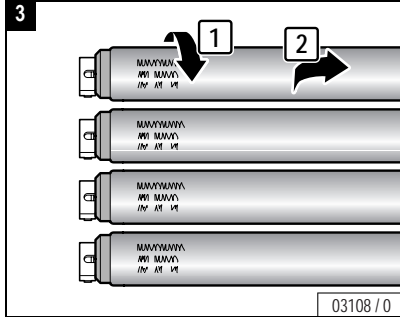
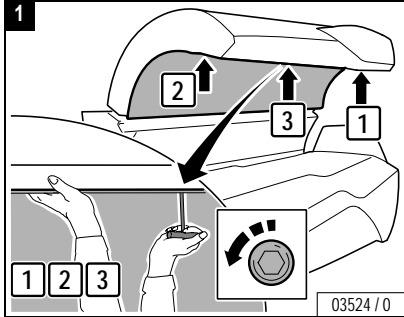

Danger of injury from the canopy panel!

WARNING! The canopy panel is heavy and falls down by itself after unscrewing the 3 screws.

- Support canopy panel.
- Loosen screws in the specified order.



Maintenance

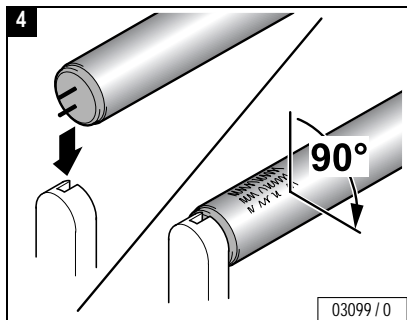

Close:

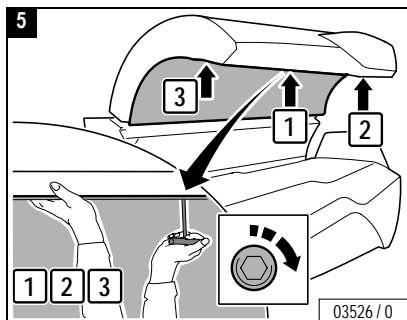

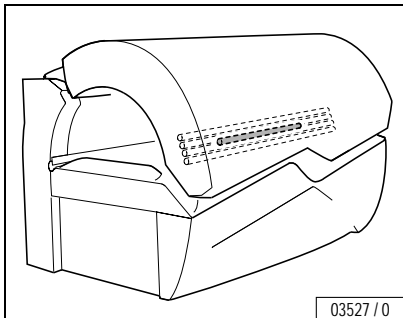
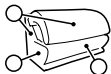

De-energize device!

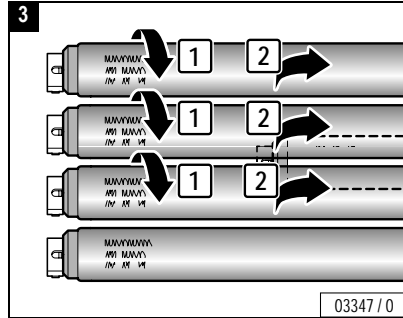
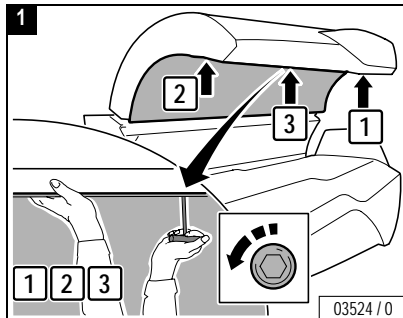

Danger of injury from the canopy panel!

WARNING! The canopy panel is heavy and falls down by itself after unscrewing the 3 screws.

- Support canopy panel.
- Loosen screws in the specified order.

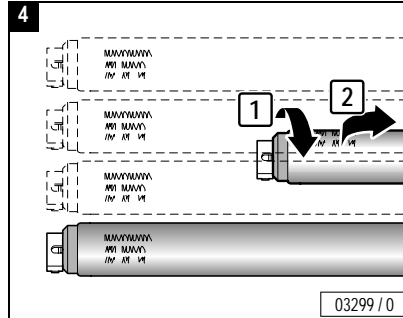
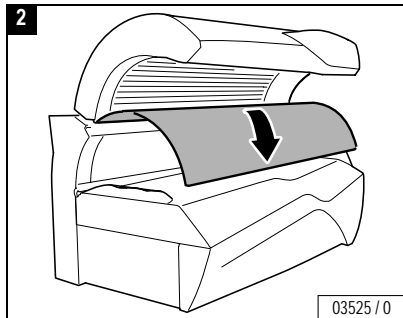

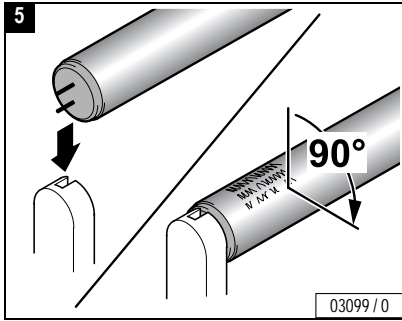

Close:

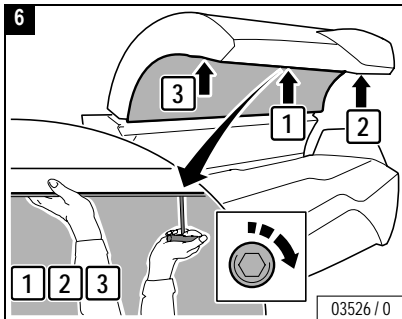



UV high-pressure lamps, side section

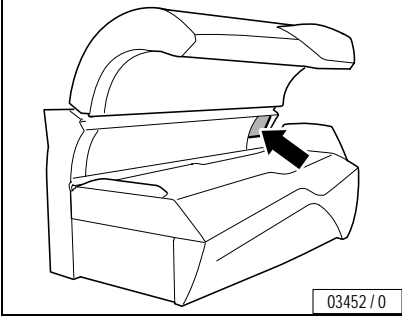
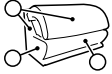

03452 / 0

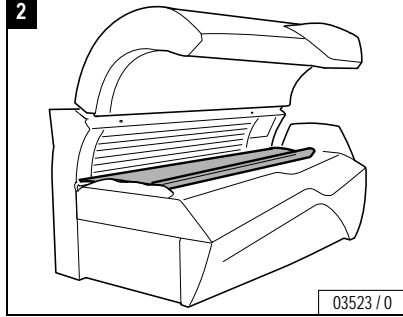

03523 / 0

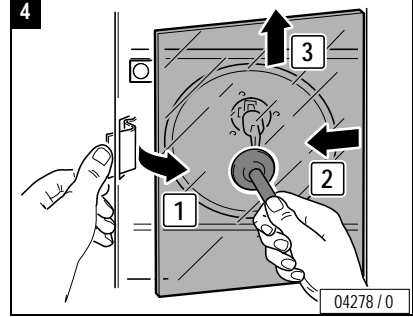

04278 / 0

Maintenance



De-energize device!

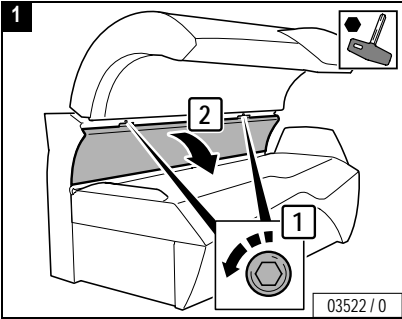

03522 / 0

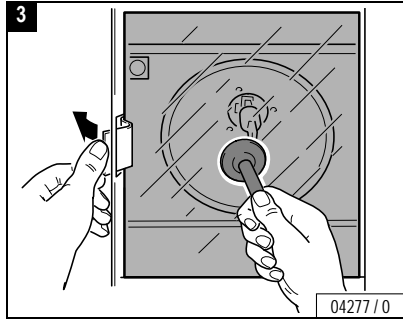

04277 / 0

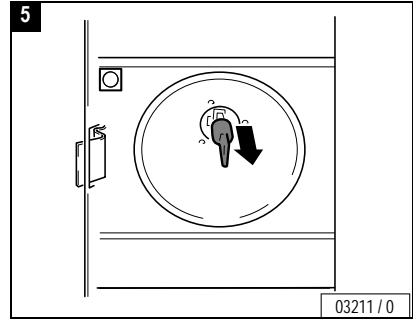

03211 / 0

...

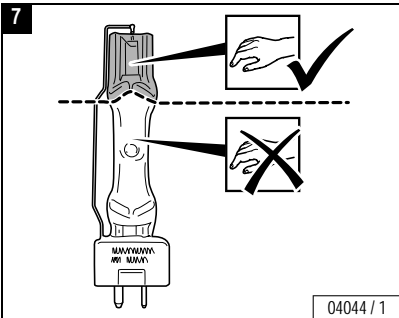
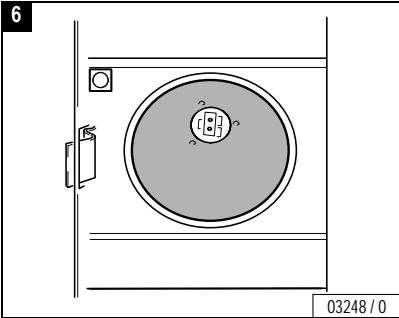

CAUTION!

Do not touch the glass bulbs of the UV high-pressure lamps with your bare fingers! Remove soiling thoroughly.

- Only touch new UV high-pressure lamp on the gripping surface - see Figures 7 and 8.

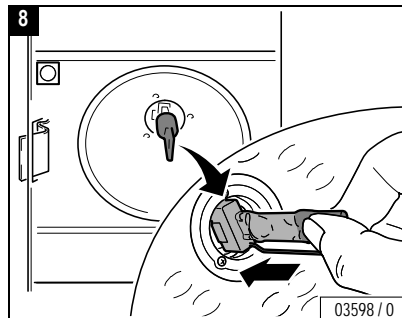

- Check safety switch:

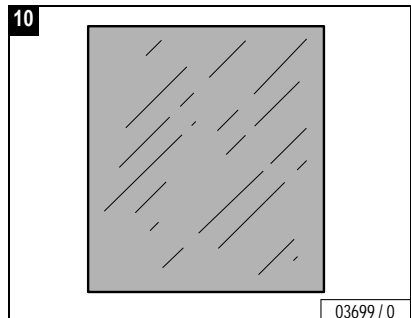
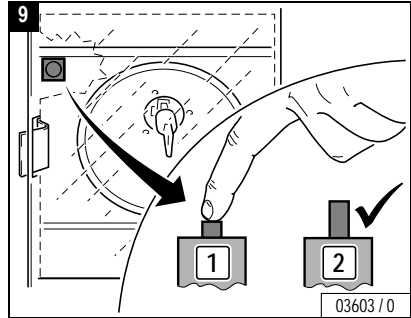



Maintenance

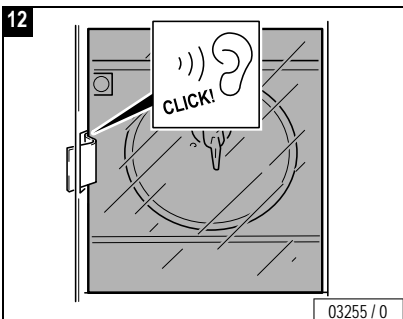
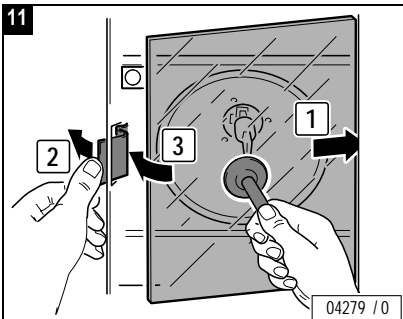

Close:

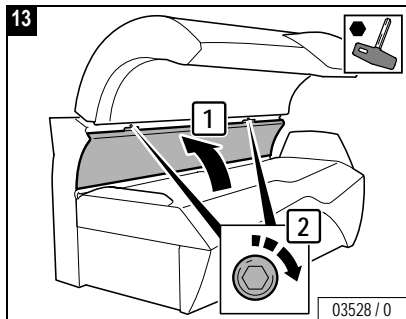

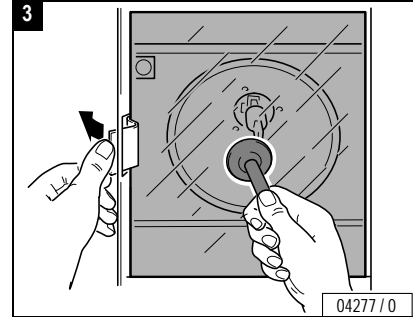
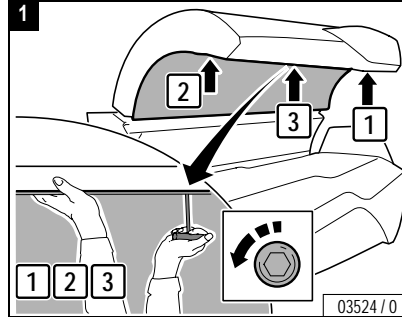
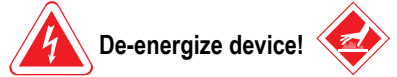
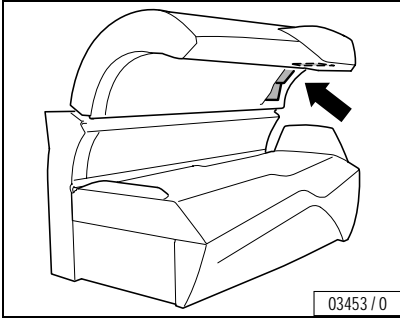



Danger of injury from the canopy panel!

WARNING! The canopy panel is heavy and falls down by itself after unscrewing the 3 screws.

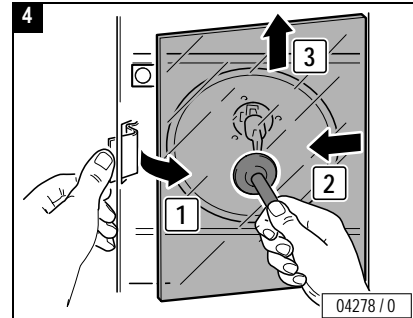
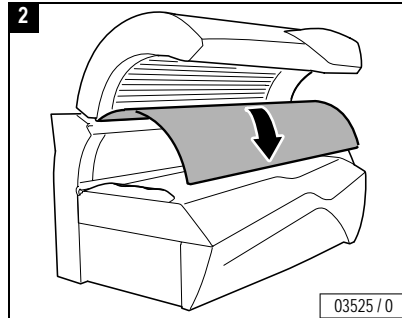
- Support canopy panel.
- Loosen screws in the specified order.

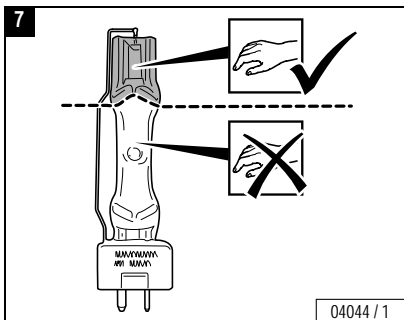
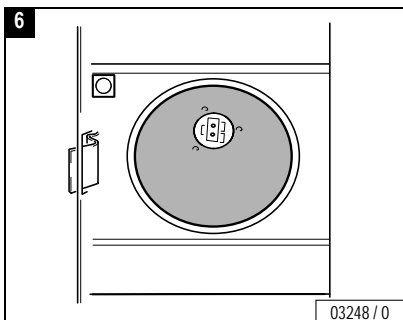
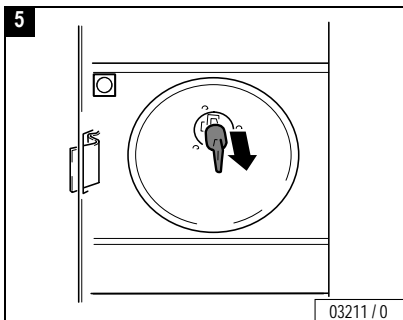

Maintenance 

**CAUTION!**

Do not touch the glass bulbs of the UV high-pressure lamps with your bare fingers! Remove soiling thoroughly.

- Only touch new UV high-pressure lamp on the gripping surface - see Figures 7 and 8.

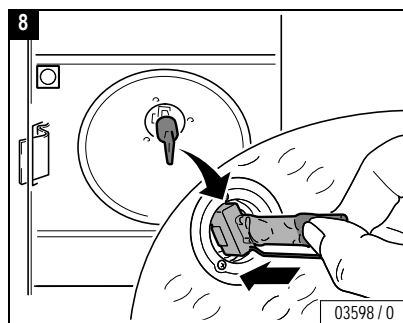

- Check safety switch:

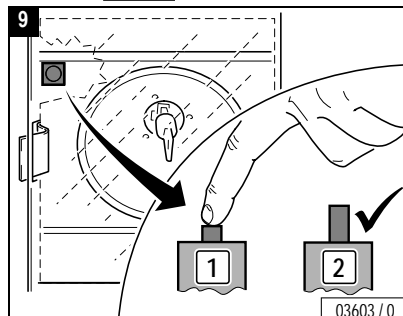

...

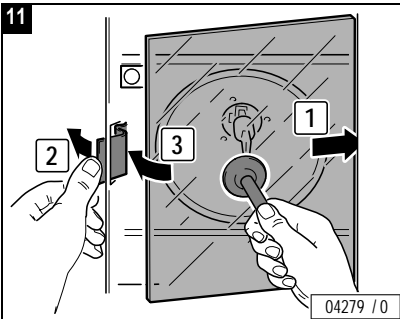
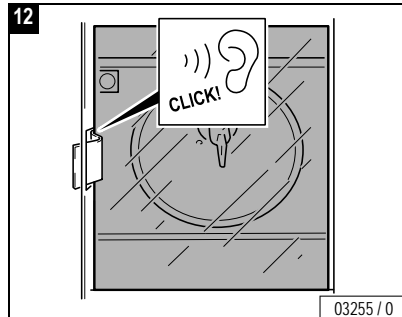
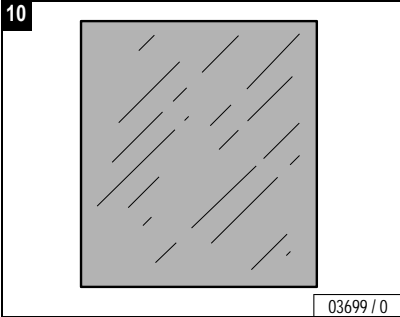

Close:

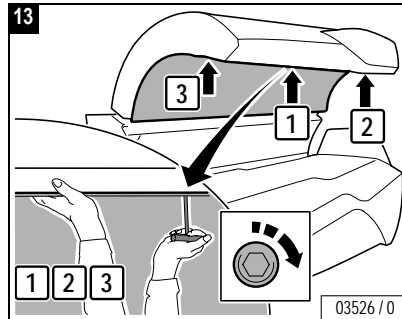



Accent lights, canopy

Maintenance

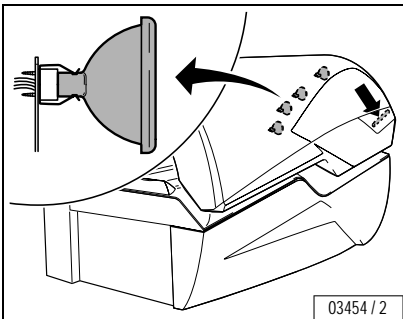
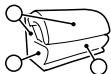

De-energize device!

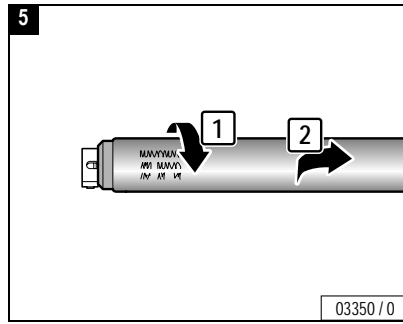
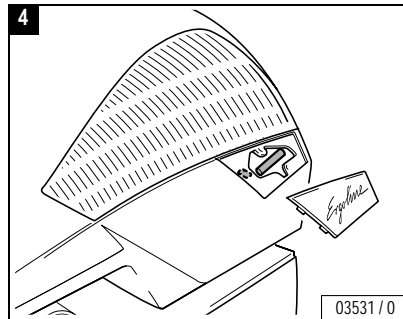
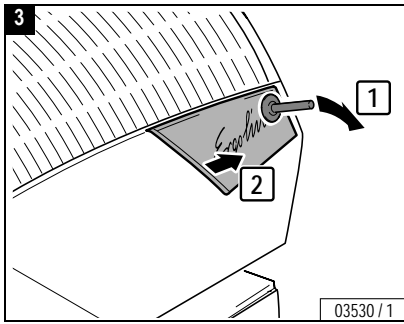
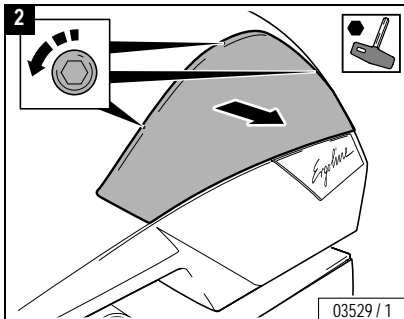
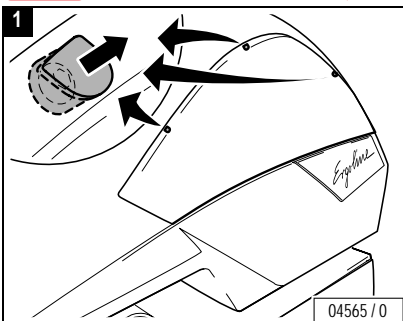

...

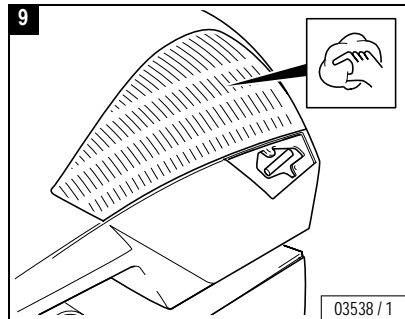
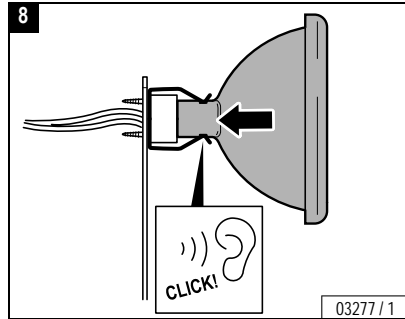
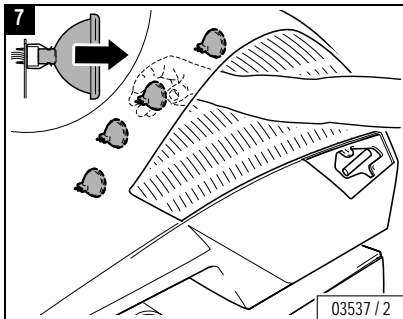
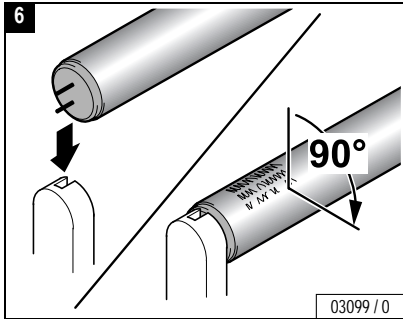

Close:

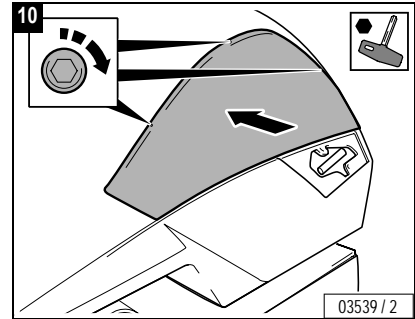

Maintenance 

...

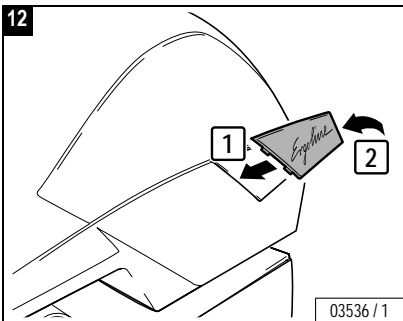
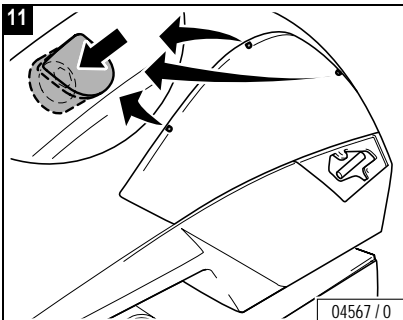



Accent lights, front panel

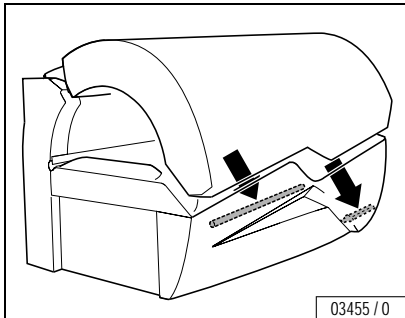
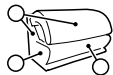

03455 / 0

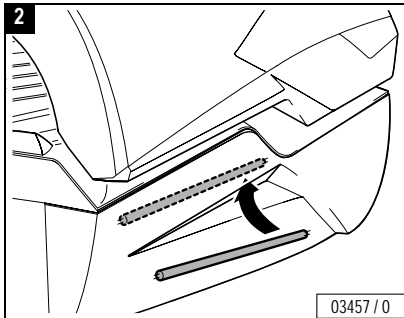

03457 / 0

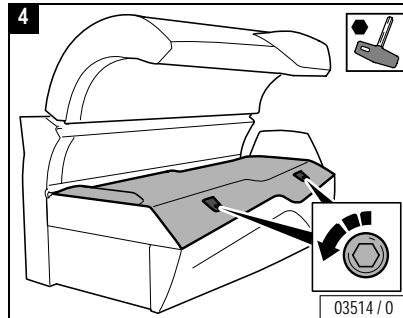

03514 / 0



De-energize device!

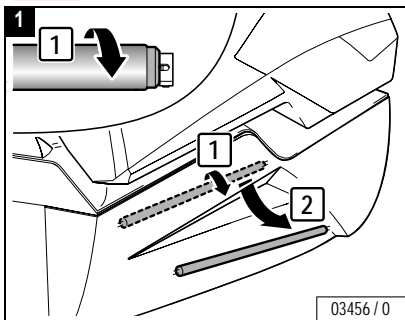

03456 / 0

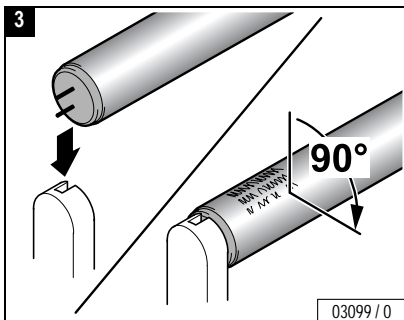

03099 / 0

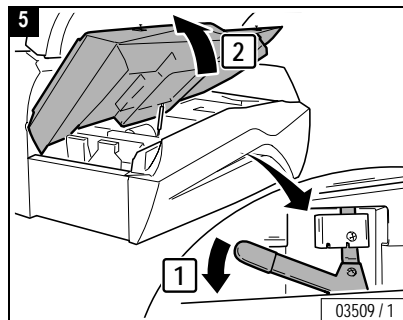

03509 / 1



Maintenance



Maintenance

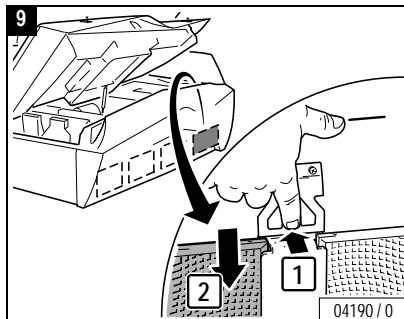
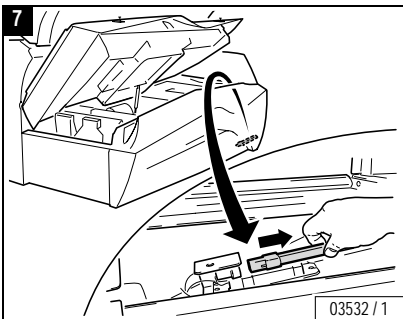
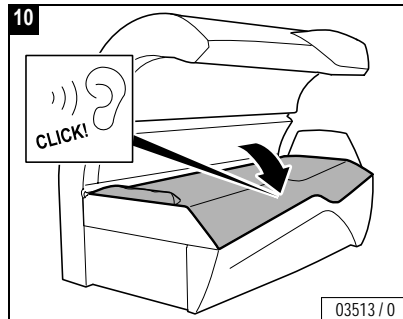
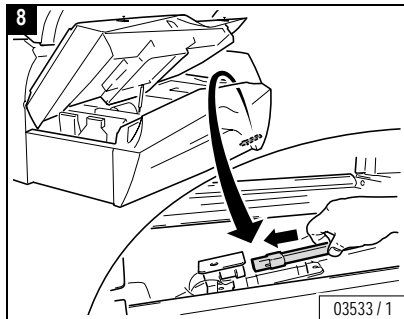
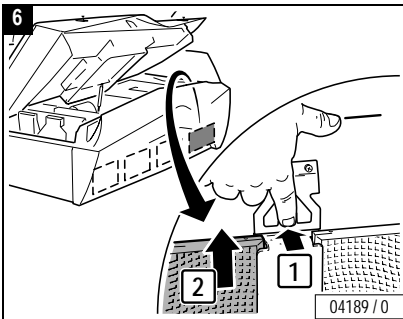

Close:

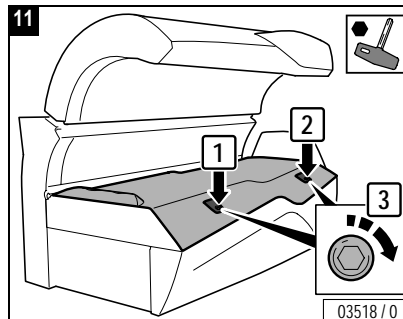



Lower section, filter

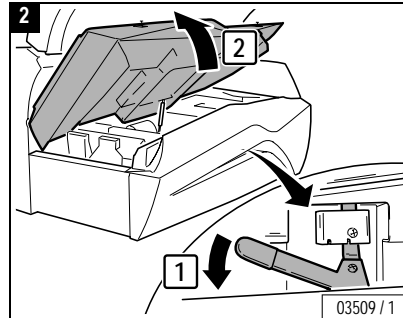
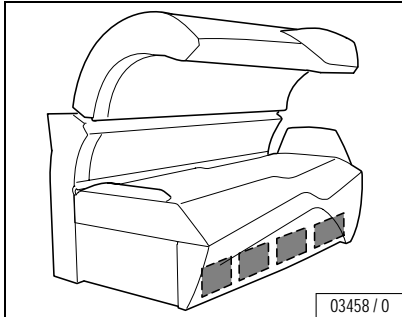
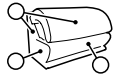

Hand-wipe lightly, dry or with water, or use a vacuum cleaner.

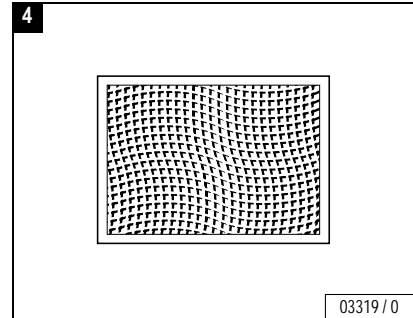

De-energize device!

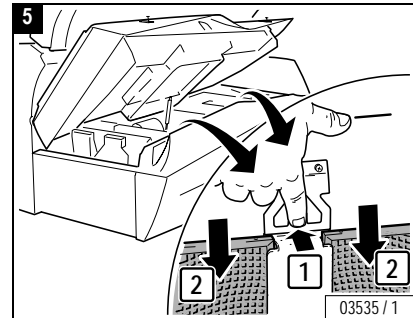
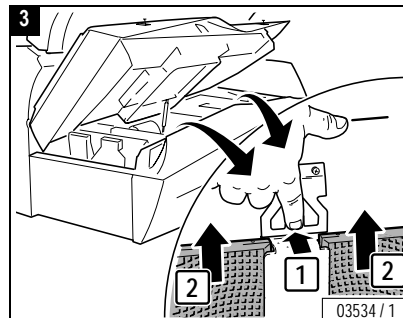
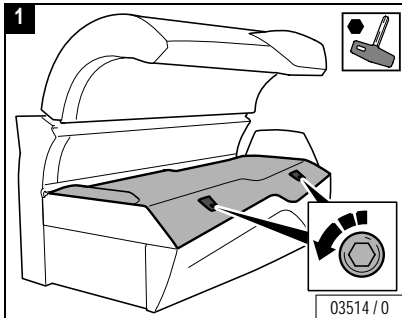

Maintenance 

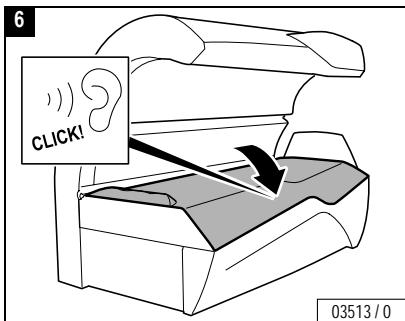

Close:

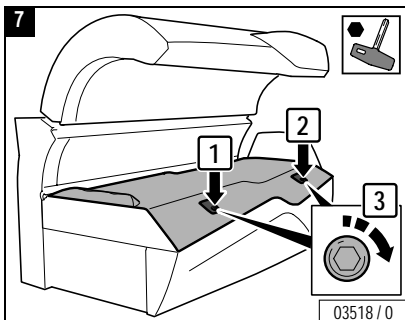



Canopy, filter mats

USA

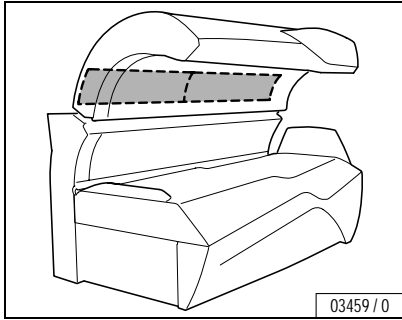
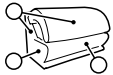

Rinse with water or replace.

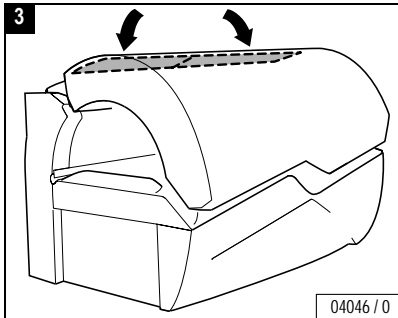
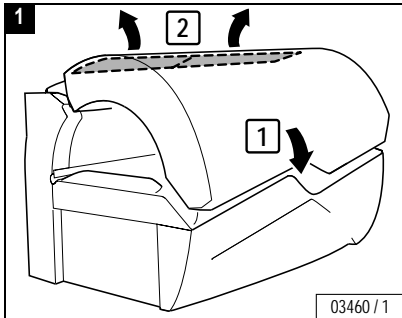
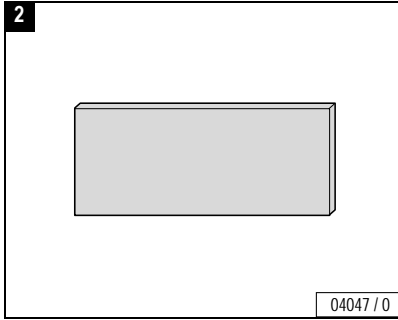

Maintenance





Shoulder tanner, filter mats

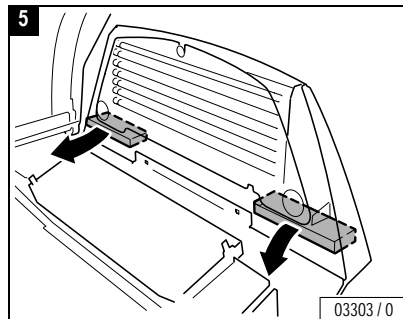
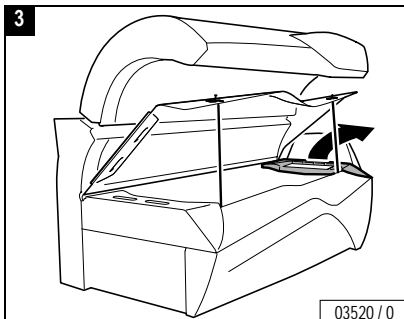
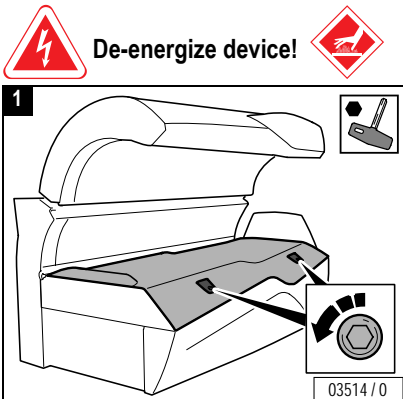
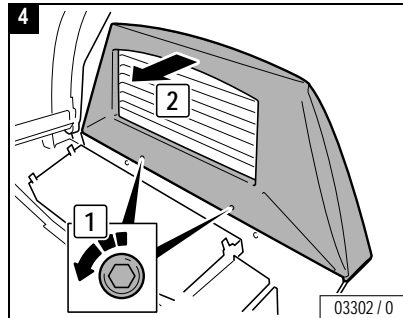
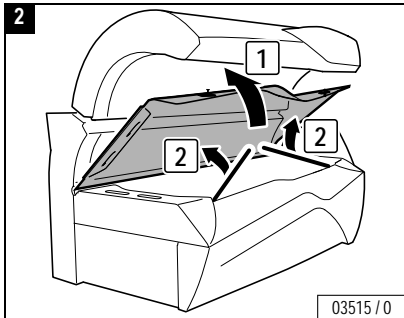
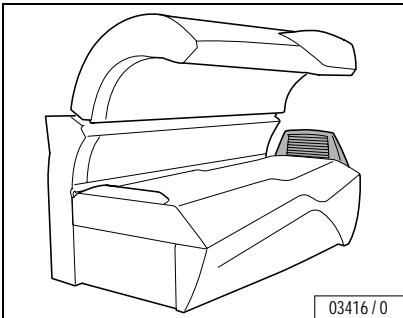
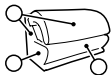

...

Maintenance



Rinse with water or replace.

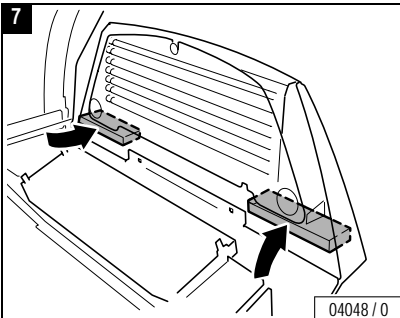
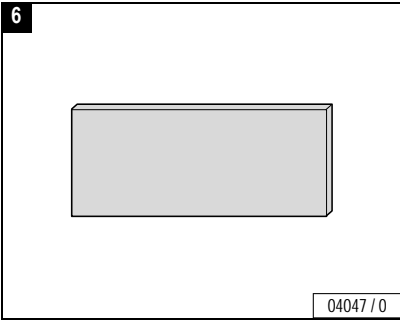

Close:

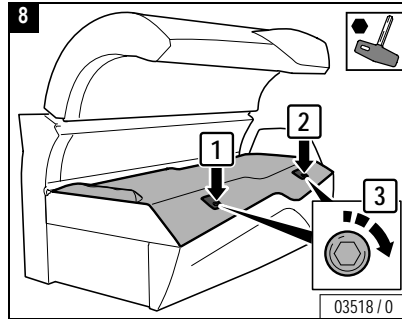



Air Condition, condensate and filter mats

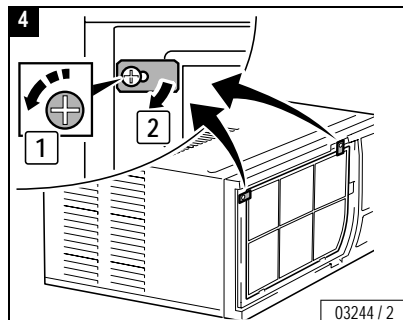
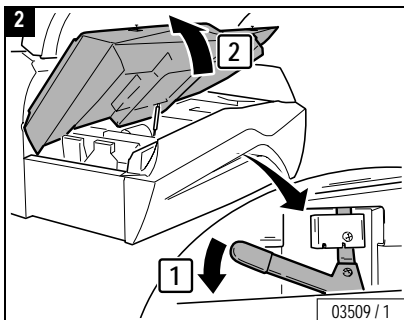
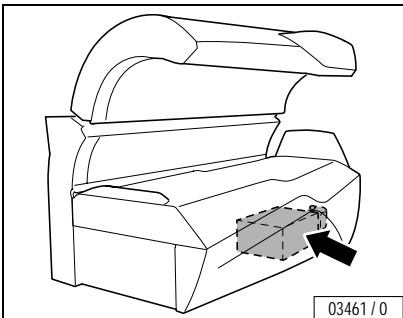
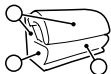

Maintenance



De-energize device!



Clean carefully (vacuum or wash) or replace.

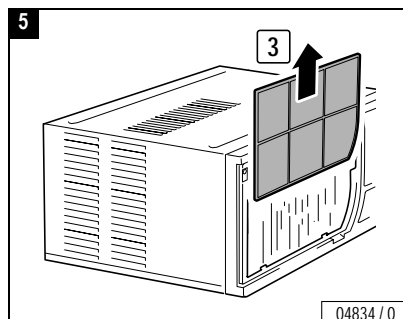
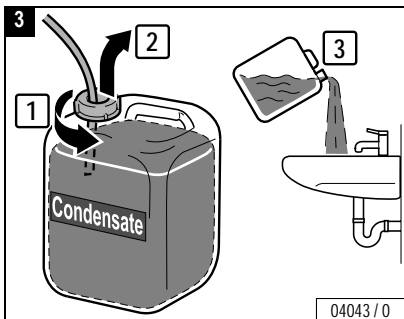
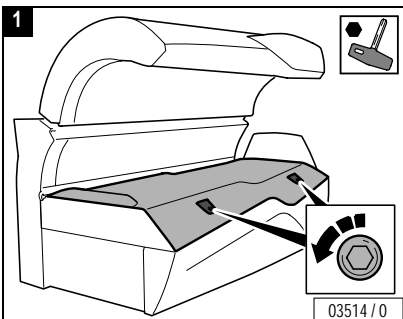

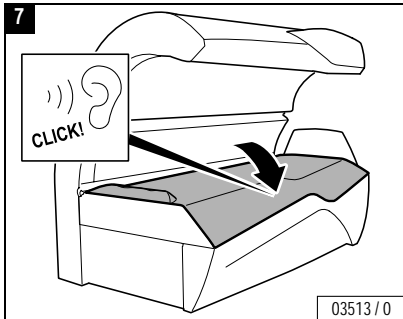
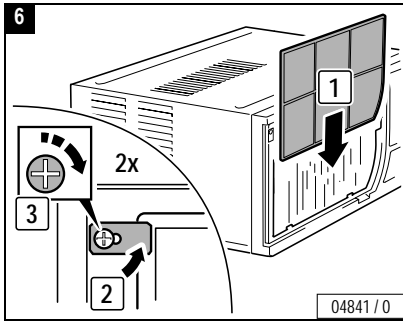

Close:

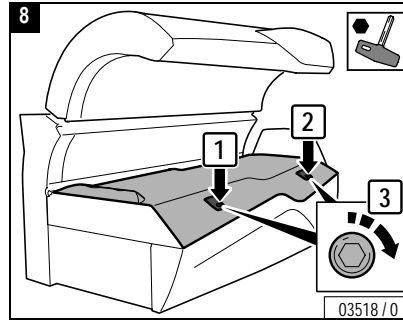



Changing presettings with the control panel

The setting mode enables you to call up operating states and make alterations to current settings. If VoiceGuide is included with the device, you can also listen to the explanations on the preadjustments.

Changing to Presetting mode

- Press the buttons - and + simultaneously for at least five seconds outside a tanning process.
- appears in the display.
- Enter the code (see Page 77).
- Press the START/STOP button four times when you run the Presetting mode for the first time.
- briefly appears in the display, then (Function 1) and the presetting value are displayed alternately (see column "On delivery").
- By pressing the + button you scroll up to the next function (from -01- to -19-).
- By pressing the – button you scroll down to the next function (from -19- to -01-).

Changing presettings

Increase the preset value:

- Press and hold the START/STOP button while simultaneously pressing the + button.

Decrease the preset value:

- Press and hold the START/STOP button while simultaneously pressing the – button.

Reset to the last value set:

- Press the START/STOP button.

Reset to the delivered state:

- See function .



Note:

The sunbed will automatically return to 'idle' mode 30 seconds after the last button was pressed.

The presettings are listed beginning on Page 79.



Defining a code

- Select Function
- Press the START/STOP button for 3 seconds until appears.
- Press the desired buttons consecutively:
- Press the buttons in the same sequence when appears again.
- appears in the display. The set code has been saved.
- Please note the code for Customer Service.

If you know the old code, you can define a new code at any time.



Changing presets with a hand-held unit

Some data can also be displayed and changed with a commercially available hand-held unit (e.g. from Palm). For this purpose you require special software (available in German and English), which you can download at www.sunergoline.com. The operating manual for this software is also available at the same website.



Caution!

The code for access via the infrared interface is preset in the software of the hand-held unit, and can therefore be used with any unit. Anyone, who downloads the software from the Internet can access the unit date with a hand-held unit. Please note that Customer Service changes the preset access code during initial start-up – see software operating manual. Please note the new code for future use!

This code is independent of the access code for the presets via the control panel.



Note:

Please read the operating manual for the software for instructions on how to display or change data with a hand-held unit.

Information on operating the hand-held unit is contained in the manufacturer's documentation.

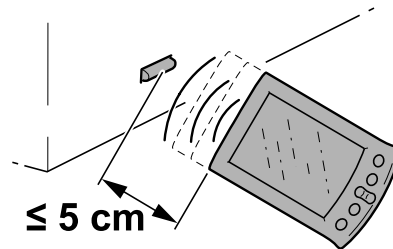

IR Function

04002 / 0



No.	Description	on delivery	Values from-to
	Total number of operating hours		0 → 9999
	Remaining operating time of UV low-pressure lamps (hours)		500 → 0000
	Remaining operating time of UV high-pressure lamps (hours)		500 → 0
	Remaining operating time of shoulder tanner (hours)		500 → 0
	Remaining operating time of filter mats (hours)		50 → 0
	Air conditioning operating hours		0 → 9999
	Accent lighting operating hours (minutes) When the maximum value is exceeded: Display = continuous operation		1 → 1440
	Fan run-on time (minutes)		3 → 10
	To set the time		1 → 23 01 → 59





No.	Description	on delivery	Values from-to
	To reset the device to ex-works setting (all functions)		
	To set the access authorisation code to enter setting mode (see Page 77)		
	Adjust volume for voice output (VoiceGuide)		7 → 63
	Adjust volume for music output (Sound System)		7 → 63
	Ambient temperature setpoint value (°C)		15 → 30
	Recycle air during fan run-on time (+ = on / - = OFF)		
	Lower temperature limit of air conditioner		15°C → 25°C



Troubleshooting

In the case of a fault, fault codes appear on the display to simplify localizing of the fault cause:

- If a fault occurs, the fault code flashes in the display.
- If several faults occur, the fault messages are displayed alternately.
- On devices with : The text messages on the current fault messages of the device can be displayed in the fault mode by pressing the  button in the direction of the arrow.
- The fault remedy is acknowledged by pressing the  button.

If the fault cannot be eliminated, inform Customer Service:



Global Service Division

#1 Walter Kratz Drive

Jonesboro, Arkansas 72401

 (800) 445 0624





Error	Meaning	Correction
	Full condensation tank (only when using an original condensate container)	Empty condensation container.
	Fault in condensation pump	
	Temperature sensor for heating (air conditioner)	
	Temperature sensor for cooling (air conditioner)	
	Fault in temperature sensor for UV low-pressure lamps	
	Temperature sensor for room	
	Panel switch for shoulder tanner	
	Air-vane switch does not switch on with fan running	
	Air-vane switch does not switch off 1 minute after fan switches off	
	Fault in front face tanner	





Error	Meaning	Correction
	Fault in centre face tanner	
	Fault in face tanner rear	
	Fault in face tanner side section	
	Panel switch on decorative panel on canopy	
	Panel switch of acrylic glass panel on sunbed base/side section	
	Emergency switch-off time exceeded	
	I ² C bus fault	
	Switching error in series circuit of safety switch	
	Auxiliary controller	
	Heating controller	





Error	Meaning	Correction
	Face tanner controller	
	Speed control 1	
	Speed control 2	
	Audio amplifier	
	Channel selection	
	Real-time clock	
	Parameter memory	
	Incorrect equipment of controller	



Index

A

Accent lights
 Operation 26
 Replacing 64, 67, 68
 Acrylic glass panels 17
 Air condition
 Condensate, filter mat 74
 Operation 29

B

Bed tolerance in room 37

C

Channel, operation 34
 Children 11
 Circuit breakers 39
 Cleaning schedules 40
 Code
 Defining a code with hand-held unit... 78
 Defining a code with operating panel. 77
 Condensate, air condition 74
 Contact 21

D

Deenergizing device 39
 Disposal of lamps 19

E

Equipment 16
 Error codes 81
 Export 16
 Exposure schedule 5
 Eye injuries 10

F

Face tanner, operation 27
 Fan delay 24
 Fault codes 81
 Filter mats
 Air condition, cleaning/replacing 74
 Canopy, cleaning/replacing 71
 Shoulder tanner, cleaning/replacing... 72

Filter panels, cleaning 60, 63
 Filter, lower section, cleaning 69
 Frequency 36
 Fusing 36

G

Global Service Division 4

H

Hand-held unit, changing presettings 78

I

INFO, operation 33
 Intended use 10
 Interior lighting 56

L

Label 4
 Load, maximum 37
 Long-term consequences 11

M

Maintenance schedules 42
 Minors 11

N

Neck tanner, lamps 49

O

Operator, important information 10
 Order numbers 42, 43, 44
 Overview
 Maintenance 40
 Operation 22

P

Palm, changing presets	78
Plastic	18
Power consumption	36
Powerinput	36
Preparation time	24
Presettings	76
Table	79

R

Relamping instructions, general	46
Room temperature, maximum	37

S

Safety information	5, 10
Settings at start	25
Shoulder tanner	
Filter mats	72
Lamps	51
Operation	28
Skin types	20
Spare parts	17
Start of tanning session	24
Sun screen	20
Surround cooling, operation	29, 30

Symbols	13
Cleaning	15
Draining	15
Ergoline key	13
Filter panel	13
Filter/filter mat	15
High-pressure lamp	13
Hot surface	13
Low-pressure lamp	13
Press button	14
Replacing	15
Safety switch	14
Starter	13
Visual inspection	15

T

Tanning instructions	19
Tanning times	5
Technical data	36
Temptronic	
Condensate, filter mat	74
Operation	29
Termination of tanning	25
Troubleshooting	81
Type label	4

U

UL Standard	16
UV high-pressure lamps	
Canopy	61
Side section	58
UV lamps, maintenance schedule	44
UV low-pressure lamps	
Canopy	54
lower section	47
Neck tanner	49
Shoulder tanner	51
side section	53

V

Ventilation	20
Voice Guide, operation	32
Voltage	36
Volume, operation	35

Warranty

SUN Ergoline – Limited Warranty

SUN Ergoline warrants its products to be free from defects in materials and workmanship under intended normal use as described in the unit's Operation and Instruction Manual, for a period of three (3) years from date of sale.

This Limited Warranty applies only to the original purchaser of the equipment through SUN Ergoline or its authorized dealer or distributor, and is not transferable.

SUN Ergoline obligations under this warranty are limited to repair or replacement of any defective part without charge for that part to the original purchaser, with the following exceptions:

- A. Fluorescent lamps are warranted against defects for a period of thirty (30) days from date of sale.
- B. Only parts obtained through SUN Ergoline, its authorized dealers or distributors may be used. Transportation costs for parts shipped to the consumer and the return of defective parts to SUN Ergoline are not included.
- C. Labor will be furnished without charge for ninety (90) days from date of purchase only. All labor and related charges must be authorized by SUN Ergoline prior to start of repairs, and must coincide with SUN Ergoline established rates and time allotment policy.
- D. Acrylic: Refer to Manufacturer's Acrylic Warranty Policy.

It is imperative that the original customer completes and returns the enclosed warranty card within 10 days after purchase to insure valid registration and coverage for potential claims.

If the warranty card is not registered, proof of purchase from SUN Ergoline or its authorized dealer or distributor will be required prior to any consideration on warranty claims. This could result in service delays.

This warranty is extended to the individual or legal entity, whose name appears on the warranty registration card filed with SUN Ergoline, or whose name appears on the original sale document and may not be transferred to any other individual or legal entity.

This warranty does not apply to any failure of the product, or any parts of the product due to alterations, modifications, misuse, abuse, accident, improper maintenance, improper installation, acts of God or if the serial number on the product has been removed, altered or defaced. Adequate packaging must be used for returned goods to prevent freight damage.

There are no warranties which extend beyond the description on the face hereof. There is no express or implied warranty of fitness or merchantability.

The remedies provided in this limited warranty are the exclusive remedies provided to the purchaser by SUN Ergoline and are provided in substitution of all other remedies. Consequential and incidental damages are excluded.

No person, firm or corporation is authorized to obligate SUN Ergoline for any liability in connection with the sale or use of these goods.



Limited Acrylic Warranty

SUN Ergoline warrants its acrylic sheets to be free from defects in material and workmanship, under intended normal use, for a period of one (1) year from date of sale of the tanning bed. Due to the tanning lotions, cosmetics, disinfectant and improper cleaners used on tanning surfaces that cannot be controlled by SUN Ergoline, after the first thirty (30) days of warranty period. Acrylic will be subject to a prorated cost to the consumer on breakage.

SUN Ergoline obligations do not include transportation charges on replacement acrylic.

SUN Ergoline assumes no liability for the cost of removing defective sheets or installing replacement sheets, nor for damage to persons or property.

To make a claim, contact an authorized dealer or distributor of SUN Ergoline or Global Service Division with the model number, the serial number, and the date of purchase of the bed in which the acrylic will be used.

There are no warranties which extend beyond the description on the face hereof. There is no express or implied warranty of fitness or merchantability.

The remedies provided in this limited warranty are the exclusive remedies provided to the purchaser by SUN Ergoline and are provided in substitution of all other remedies. Consequential and incidental damages are excluded.

Global Service Division

#1 Walter Kratz Drive
Jonesboro, Arkansas 72401

☎ (800) 445 0624

Warranty

Warranty Claims

Policy & Procedures

1. When to file a Warranty Claim:

In the event that your tanning system is not functioning properly under intended normal use as described in the unit's Operation an Instruction Manual, you may then have established cause to file a Warranty Claim.



NOTE: Both the tanning system and legal registered owner must meet the criteria established under SUN Ergoline Limited Warranty as described in this manual before any Warranty Claim will be considered.

2. Where to call to place a Warranty Claim:

SUN Ergoline is supported nationwide by an extensive dealer/distributor network through whom the majority of our units are sold. These dealers/distributors are required by contract to stock sufficient parts to meet the various warranty and nonwarranty needs of their customers.

Therefore, in order for you to properly file a Warranty Claim, you must locate the name and phone number of the dealer/distributor through whom you purchased your unit. Normally this information can be easily located either on your paid invoice or other proof of purchase documentation that you received when taking delivery of the unit.

Next, notify the dealer/distributor of the serial number, model number and date unit was purchased. This will initiate the Warranty Claim process.

Upon determination of the problem, your dealer/distributor can then supply you with the part(s) and proper instructions to return your unit to work-

ing order.

Each dealer/distributor has their own internal procedure for handling Warranty Claims and credits.

NOTE: SUN Ergoline, the manufacturer, does not involve itself in the direct handling of a Warranty Claim except where mitigating circumstances apply and where required by law.

Parts Warranty Claim/Credit Review

1. Customer calls SUN Ergoline and notifies the Service Department of problem
2. SUN Ergoline Service Department determines course of action.
3. SUN Ergoline ships part and R.A.I. to customer freight collect and bills customer on net30 basis for part only.
4. Customer, within 15 days of receiving new part, returns defective part to SUN Ergoline along with R.A.I.
5. Upon receipt of defective part and R.A.I., SUN Ergoline issues customer a credit invoice which offsets original bill. Customer's account is returned to zero balance concerning this claim.



NOTE: If part returned to SUN Ergoline proves to be operational and not defective, or if product code numbers on part do not correspond with individual unit date on file with SUN Ergoline, then a 30% restocking fee will be charged in addition to the retail purchase price of part.

Warranty

Acknowledgment of the Agreement is not required for acceptance of the foregoing stipulations.

Labor Warranty Claim/Credit Procedures

SUN Ergoline furnishes labor without charge for a period of 90 days from date of purchase. All labor and related charges must be authorized by SUN Ergoline prior to start or repairs, and must coincide with SUN Ergoline established rates and time allotment policy.

Please contact our Service Department for authorization and billing procedures.

Limited Lifetime Warranty

SUN Ergoline warrants specific individual components of the Competition Tanning Systems against defects in materials and workmanship for the life of the product. Coverage is limited to units purchased after November 1, 1994.

This warranty is restricted by the following components only:

- Steel Back Panels
- Structural Steel Frame Components
- Exterior Steel Body



NOTE: Components are warranted on an individual basis and not as they may effect the complete product.

Warranty coverage does not include cosmetic abnormalities such as scratches, nicks, dents, oxidation of paint or other cosmetic changes that

do not interfere with the designed function of the unit.

This warranty does not include failure of the product due to alteration, modifications, misuse, abuse, improper maintenance, improper installation or repair.

This warranty is not transferable and is only applicable to the original purchaser named on a completed and registered warranty record at SUN Ergoline headquarters.

SUN Ergoline obligations do not include transportation charged on the shipping of new components to the customer or on the return of defective components of the manufacturer. All freight charges must be paid by the customer.

There are no warranties which extend beyond the description on the face hereof. There is no express or implied warranty of fitness or merchantability.

The remedies provided in this limited warranty are the exclusive remedies provided to the purchaser by SUN Ergoline and are provided in substitution of all other remedies. Consequential and incidental damages are excluded.



Notice: Any misuse, abuse, modification, alteration, improper maintenance, improper installation, etc. of this product or its intended use will subject said party to direct responsibility and liabilities for any and all consequences resulting from such action. Furthermore, such actions will void all warranties and may relieve SUN Ergoline of any liabilities relating to said product.

Ergoline Excellence

Instructions d'utilisation



Excellence 800 Turbo Power
VHP 12

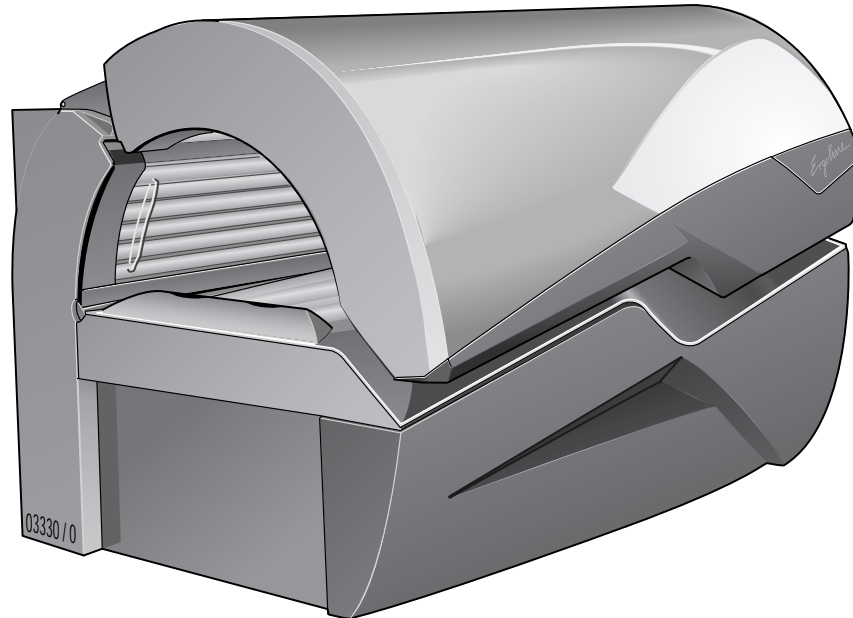

Identifiez votre solarium

Veillez noter le numéro de série de votre solarium lorsque vous contactez le service après-vente.

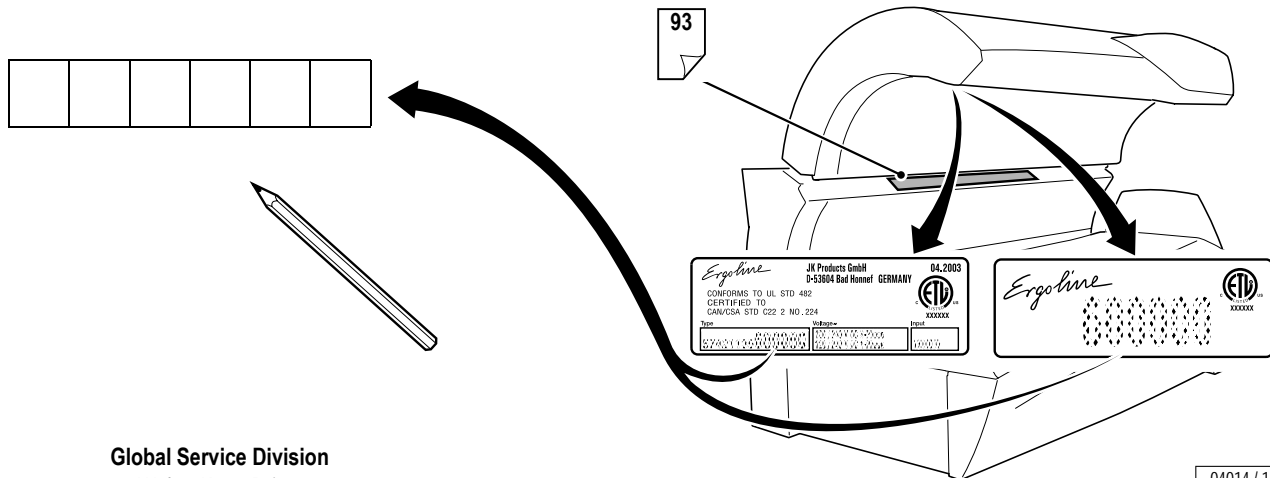

Global Service Division
#1 Walter Kratz Drive
Jonesboro, Arkansas 72401

04014 / 1



 (800) 445 0624

DANGER DE RADIATION AUX RAYONS ULTRAVIOLETS

Suivre les instructions suivantes: Eviter la surexposition comme au soleil. La surexposition peut provoquer des lésions aux yeux comme à la peau ainsi que des réactions allergiques. Une surexposition peut avoir pour effet un vieillissement prématuré de la peau de source cancérogène.

Le temps d'exposition maximum est de 12 minutes.

Tableau des expositions recommandées

Type de peau	1 ^{ère} semaine	2 ^{ème} semaine	3 ^{ème} semaine	4 ^{ème} semaine	Séances hebdomadaires par la suite
	1 ^{ère} - 3 ^{ème} exposition	4 ^{ème} - 6 ^{ème} exposition	7 ^{ème} - 10 ^{ème} exposition	11 ^{ème} - 15 ^{ème} exposition	
II - sensible	2 min.	5 min.	8 min.	10 min.	12 min.
III - moyenne	2 min.	5 min.	8 min.	10 min.	12 min.
IV - brune	2 min.	7 min.	10 min.	12 min.	12 min.
V - brun foncé	2 min.	7 min.	10 min.	12 min.	12 min.

Portez des lunettes protectrices! Ne pas le faire peut provoquer des brûlures sévères et occasionner des lésions (irréversibles) aux yeux.

Certains médicaments ou produits cosmétiques peuvent également augmenter votre sensibilité aux rayons ultraviolets. Si vous prenez des médicaments ou si vous pensez être particulièrement sensible à une exposition au soleil, veuillez consulter un médecin avant toute exposition aux rayons ultraviolets. Notez scrupuleusement l'origine de vos problèmes de peau si vous êtes spécialement sensible aux rayons du soleil. Si vous ne bronzez pas au soleil, vous ne bronzeurez probablement pas avec cet appareil!

Cette unité utilise des lampes UVA . Remplacez les uniquement avec des Ergoline VHP 12 160W Turbo Power, Ergoline VHP 25W Power (bronzage des épaules et du cou) et JK Ergoline 500 SE C11292 (haute pression) ou autres lampes reconnues équivalentes.

Pour obtenir la distance minimum recommandée d'exposition de 13mm mesurée à l'aide d'une règle usuelle, allongez-vous sur la banquette acrylique et rabattez le couvercle. Le couvercle s'arrêtera à la distance correcte de la surface de la banquette acrylique.

Attention: l'utilisation de toute autre position peut provoquer une surexposition.

Le bronzage peut débuter sur une base d'expositions régulières. L'apparition du bronzage se fait remarquer normalement après quelques expositions et au maximum 4 semaines suivant l'exposition selon le tableau ci-dessus pour chaque type de peau. Afin de procurer et conserver un bronzage minimum, deux séances de 12 minutes au maximum par semaine sont recommandées à partir de la cinquième semaine.

Utiliser des lunettes protectrices (Type no Schmerler 2255 Rouge ou équivalentes), lorsque l'équipement est en fonctionnement. Lire attentivement et suivre les instructions du petit manuel avant d'utiliser le produit. Afin d'éviter une décharge électrique lors du service de maintenance, veillez à déconnecter l'appareil du courant électrique. 801833



Note:
Description des types de peau, voir page 108.

06122 / 0

« En termes de performances standard, ce produit est conforme aux exigences applicables aux appareils équipés de lampes à rayons ultraviolets selon la norme CFR21 Part 1040. »

Cher client,

L'appareil Ergoline que vous avez acheté est un système de commande à ordinateur performant et intégrant les dernières avancées de la technologie. La fabrication de votre appareil a fait l'objet d'un soin et d'une précision extrêmes. Il a été soumis à un contrôle qualité rigoureux et à de nombreux tests de sécurité afin d'en garantir le fonctionnement sûr et sans problèmes. Vous restez néanmoins un acteur important pour garantir la longévité de votre appareil. Si vous suivez les conseils et les informations spécifiés dans les instructions d'installation, votre appareil vous apportera entière satisfaction.

Nous sommes toujours à votre disposition si vous avez des questions¹⁾.

Avec nos meilleures salutations

SUN Ergoline

- Lisez et observez les informations contenues dans ce manuel d'instructions. Elles vous permettent d'éviter les accidents et d'avoir un appareil en parfait état de fonctionnement.
- Tenez toujours également compte des réglementations et prescriptions légales générales ou autres, ainsi que les directives de protection de l'environnement.

1) ☎ (800) 643 0086

Table des matières

Utilisation conforme	98	Réglage des bronzers faciaux	115
Notes relatives aux dangers, blessures corporelles :	98	Allumage et extinction du bronzeur pour épaules.	116
Signification des symboles	101	Réglage du système Temptronic ¹⁾ (air conditionné).....	117
Directives	104	Réglage de la ventilation corporelle	118
Exportation	104	Réglage de la ventilation faciale	119
Equipement	104	Voice Guide	120
Accessoires	104	Ecoute des textes d'information INFO	121
Information sur le produit	105	Sélection des chaînes musicales	122
Maintenance et entretien	105	Réglage du volume.....	123
Nettoyage	106	Caractéristiques techniques.....	124
Information relative à la protection de l'environnement	107	Maintenance	Page dépliant, 127
Notice générale pour le bronzage	107	Maintenance, vue d'ensemble	127
Types de peau	108	Intervalles de maintenance, lampes installées et numéros d'ordre .	128
Service	109	Nettoyage/remplacement des lampes UV basse pression	
Tableau de service.....	Page dépliant, 109	dans la partie inférieure du solarium.....	135
Vue d'ensemble	109	Nettoyage/remplacement des lampes UV basse pression	
Accessoires	111	dans le bronzeur pour nuque	137
Réglages pendant le démarrage	113	Nettoyage/remplacement des lampes UV basse pression	
Fin de la séance de bronzage	113	dans le bronzeur pour épaules	139
Durée de fonctionnement des lampes décoratives	114		
Fonction IR	114		

1) option

Nettoyage/remplacement des lampes UV basse pression dans la partie latérale	141
Nettoyage/remplacement des lampes UV basse pression dans la partie supérieure	142
Nettoyage/remplacement de l'éclairage intérieur	144
Nettoyage/remplacement des lampes UV haute pression/panneaux filtrants dans la partie latérale	146
Nettoyage/remplacement des lampes UV haute pression/panneaux filtrants dans la partie supérieure	149
Nettoyage/remplacement des lampes décoratives dans la partie supérieure	152
Nettoyage/remplacement des lampes décoratives dans le panneau frontal	155
Nettoyage des filtres dans la partie inférieure du solarium	157
Nettoyage/remplacement des nattes filtrantes dans la partie supérieure	159
Nettoyage/remplacement des nattes filtrantes dans le bronzeur pour épaules	160
Air conditionné : nettoyage/remplacement de natte filtrante, vidage du réservoir à condensat	162
Réglages préliminaires	164
Réglages préliminaires via le tableau de commande	164
Réglages préliminaires à l'aide d'un ordinateur de poche	166

Dépannage	169
Index alphabétique	173
Garantie	175
Service avec minuterie	voir manuel séparé

**Note :**

Les illustrations et les informations fournies dans le présent mode d'emploi le sont sous réserve de modifications techniques. Toute reproduction ou duplication, partielle ou complète, de ce manuel n'est autorisée qu'après autorisation écrite préalable et avec référence à la source.

Notes relatives à la sécurité

Description des panneaux d'avertissement

Notes relatives aux dangers, blessures corporelles :



Type et source de danger, par ex. « DANGER – haute tension ! »

DANGER !

Description des conséquences, par ex. « Danger de mort ou de blessures des suites d'un choc électrique ! »

Contre-mesures :

- Débranchez l'appareil de l'alimentation secteur avant l'ouverture.
- N'intervenez pas à l'intérieur et ne changez pas de lampes quand l'appareil est sous tension.

Notes d'avertissement, blessures corporelles :



Type et source de danger, par ex. « Avertissement – surface chaude ! »

AVERT. !

Description des conséquences, par ex. « Risque de brûlures aux mains (peau, visage) ! »

Contre-mesures :

- Ne touchez pas aux lampes et aux surfaces avoisinantes.
- Attendez que les lampes et les surfaces soient refroidies.

Notes de prudence, dommages matériels :



ATTENTION !

Le mot « ATTENTION » sur cette étiquette indique un danger potentiel pour les équipements, le matériel et l'environnement.



Information importante :

Note :

Ce symbole ne concerne pas les notes relatives à la sécurité ; il ne fournit que des informations pour mieux comprendre les processus.

Utilisation conforme

Le solarium est conçu exclusivement pour le bronzage cosmétique du corps humain.

- Cet appareil est utilisé pour le bronzage d'une personne adulte à la fois.
- L'utilisateur porte des lunettes de protection des yeux neutralisant les rayons UV pendant le bronzage.

Toute utilisation autre est considérée comme non conforme. Le constructeur décline toute responsabilité pour les dommages ou blessures susceptibles d'en résulter. L'utilisateur est seul responsable.

Par utilisation conforme, on entend également le respect des remarques, conditions d'utilisation, d'entretien et des prescriptions du constructeur. Le service, l'entretien et la remise en état de l'appareil sont réservés aux personnes familiarisées avec ces tâches et instruites des risques éventuels.

Notes importantes à l'intention de l'exploitant du studio

- En tant qu'exploitant, vous êtes tenu d'informer les utilisateurs sur les risques éventuels pendant le bronzage.
- Toutes les indications relatives aux dangers et à la sécurité sur l'appareil doivent être observées. Ne pas les enlever !
- Aucun équipement de sécurité (par ex. interrupteur de panneau) ne doit être enlevé ou désactivé pour ne pas nuire à un fonctionnement sûr de l'appareil !
- L'appareil ne doit être utilisé que lorsqu'il est en parfait état de fonctionnement !

Notes relatives aux dangers, blessures corporelles :



DANGER !

DANGER – haute tension !

Danger de mort ou de blessures des suites d'un choc électrique !

Le montage et les branchements électriques doivent être effectués de façon conforme aux réglementations nationales et locales.

- Le montage, l'installation, la mise à niveau et la réparation de l'appareil doivent être exclusivement réservés à un personnel formé et instruit en conséquence.



AVERT. !

Avertissement – rayons ultraviolets !

Un bronzage sans protection peut entraîner des blessures et des dommages des yeux.

L'œil non protégé peut subir une inflammation en surface avec, dans certains cas, un endommagement de la rétine des suites d'un rayonnement excessif. Des cataractes peuvent se former après une exposition fréquente aux rayons.

- Informez les utilisateurs pour les prévenir de fermer les yeux et d'utiliser les lunettes de protection fournies contre les UV (n° de commande 84592¹⁾).

1) **Global Service Division** – cf. page 92.



AVERT. !

Avertissement – rayons ultraviolets !

Comme avec les rayons du soleil, une surexposition peut causer des dommages des yeux et de la peau, ainsi que des allergies. Une exposition répétée peut entraîner un vieillissement anticipé et un cancer de la peau. L'absence de lunettes de protection peut être la cause de graves brûlures et d'endommagements à long terme des yeux.

Les personnes utilisant le solarium pourront noter occasionnellement de légères rougeurs de la peau – normalement par petites taches – après la deuxième ou la troisième séance. Ces rougeurs s'accompagnent fréquemment de démangeaisons. Ceci ne peut être rien d'autre qu'une inflammation due à la chaleur dégagée par les lampes dans l'appareil. Elle est en règle générale très limitée et causée par le contact constant de la peau et de la surface acrylique. Elle disparaît normalement au bout d'environ 24 heures et ne réapparaît pas. Cette éruption peut être réduite ou empêchée par l'application d'une lotion hydratante sur la zone affectée une fois la séance de bronzage terminée.

– Suivre les instructions.

– L'intervalle entre deux séances de bronzage doit être d'au moins 24 heures !

- L'augmentation du bronzage requiert également une augmentation du temps d'exposition (= durée de radiation) ou une nouvelle intensification n'est plus possible une fois un certain degré de bronzage atteint. Toutefois la durée d'exposition au rayonnement ne doit pas être prolongée sans considération à l'intérieur des limites de rayonnement tolérable. En conséquence, les sujets ne peuvent parvenir qu'à un certain degré de bronzage en fonction de leur type de peau, sans risque pour leur santé.
- Informer les utilisateurs sur le bronzage correct – cf. page 107.



AVERT. !

Avertissement – rayons ultraviolets !

Danger de conséquences à long terme.

- Les nourrissons et les petits enfants jusqu'à 7 ans ne doivent pas utiliser cet appareil.
- Ce qui suit concerne les mineurs de moins de 18 ans : n'utilisez les solariums qu'avec l'autorisation d'un parent ou d'un tuteur, ou après avoir consulté un médecin
- Bien qu'il n'existe pas de symptôme clinique immédiat des suites de l'exposition aux UVA et de ses effets sur les femmes enceintes, il est fortement recommandé de déconseiller l'utilisation du solarium à ces femmes.

**Danger – Risque d'infection !****DANGER !**







Les infections peuvent se propager par contact de la peau.







Tous les articles et équipements avec lesquels l'utilisateur peut entrer en contact pendant la séance de solarium doivent être désinfectés au terme de chaque séance de solarium.

- Lunettes de protection
- Repose-tête
- Partie inférieure du solarium en matériau acrylique
- Panneau de manipulation et de commande

Signification des symboles

Symboles de description, utilisation et maintenance

Symboles généraux	
	Informez le service après-vente
	Clé Ergoline
	Ne pas toucher, surface chaude !
	Lampe(s) basse pression
	Lampe(s) UV basse pression
	Starter pour lampe(s) UV basse pression
	Lampe(s) UV haute pression

Symboles généraux	
	Lampe décorative
	Lampe(s) halogène(s)
	Panneaux filtrants
	Produits de nettoyage et de désinfection
	Numéro de pièce/article (pour commandes)
Service	
	Affichage de la durée de bronzage

 Affichage du temps de poursuite (poursuite du ventilateur)

 Affichage de défaut (exemple)

 Affichage de piste d'information 1

 Affichage de chaîne musicale 1 (canal 1)
Réglage d'usine : 1 canal
Le SAV peut régler jusqu'à 7 canaux

 Affichage au réglage du volume

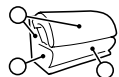

Description



Eclairage décoratif



Appuyer sur le bouton



par
ex.
2s

Appuyer sur le bouton pendant 2 secondes



Durée : 3 minutes



Haut-parleur



Raccordement d'écouteur

Caractéristiques techniques



Maintenance



Attention, interrupteur de sécurité !



Dévisser/desserrer vis











Visser/serrer vis



Ventouse

Veillez lire et observer ...

	Nettoyage
	Remplacement
	Nettoyer ou remplacer selon l'encrassement
	Vidage
	Contrôle visuel
	Air conditionné
	Filtre/natte filtrante
...	Poursuite des travaux à la page suivante
	Fin de l'étape de travail

Réglages préliminaires	
Dépannage	

Directives

Cet appareil a été construit conformément à la norme UL STD 482, certifiée CAN/CSA STD C22.2 2 No. 224.



ATTENTION – entrée et sortie d'air

Ne modifiez, bouchez ou bloquez pas l'entrée et la sortie d'air vers l'appareil et ne procédez à aucune transformation non autorisée de l'appareil. Le constructeur décline toute responsabilité pour les dommages ou les blessures susceptibles d'en résulter.

Exportation

Nous souhaitons attirer l'attention sur le fait que ces appareils sont prévus exclusivement pour être utilisés aux USA et au Canada et qu'ils ne peuvent être exportés et utilisés dans aucun autre pays ! Le constructeur décline toute responsabilité en cas de non-observation de ces prescriptions ! Nous insistons explicitement sur le fait sur les risques élevés concernant la responsabilité de l'exportateur et/ou de l'exploitant en cas de non-observation de cette indication.

Équipement

L'équipement des appareils diffère selon le modèle.

Dans ce mode d'emploi tous les composants/fonctions standard et en option et devant être observés pendant la maintenance sont pris en compte.

Le panneau de commande est également concerné par ces différents équipements. Seuls les boutons pouvant être actionnés sont visibles, c'est-à-dire que la fonction correspondante doit faire partie de l'équipement de l'appareil.

Accessoires

Certaines pièces accessoires sont prises en compte dans le plan de maintenance débutant à la page 130, mais cela ne signifie pas nécessairement que votre appareil comporte cet équipement (par ex. Temptronic).

Une vue d'ensemble des accessoires possibles est fournie dans la documentation de vente.

Veillez lire et observer ...

Information sur le produit

Panneaux en verre acrylique

Les panneaux en verre acrylique des solariums sont fabriqués dans un matériau spécialement développé pour cette application. Les acryliques utilisés se caractérisent par une perméabilité et une résistance aux UV particulièrement élevées, ainsi que par un entretien aisé ; la surface hygiénique est agréable à la peau.

Les panneaux en verre acrylique sont formés pour l'appareil respectif au cours d'un processus de protection technique sophistiqué. En dépit du savoir-faire de pointe en production, la présence de taches mineures, de bulles d'air ou de stries dans les panneaux acryliques est inévitable. De fines fissures peuvent en outre apparaître en service à la surface de la banquette.

Ces phénomènes dépendent du matériau et sont inévitables lors du traitement, mais ils restent sans effet significatif sur la valeur d'utilisation et ne peuvent pas conséquents pas être considérés comme des défauts.



ATTENTION !

Les produits cosmétiques ou crèmes solaires doivent être enlevés avant la séance de bronzage car ils peuvent entraîner à long terme des endommagements (p. ex. fissures de surface).

Maintenance et entretien



DANGER !

Danger extrême ! Haute tension !

Pendant les travaux de maintenance, risque de contact avec les pièces sous tension et de choc électrique mortel.

- Débranchez l'appareil de l'alimentation secteur avant de l'ouvrir – cf. également Page 127 !
- N'intervenez pas au-delà des recouvrements et n'ouvrez pas l'appareil quand il est sous tension.

La maintenance et l'entretien jouent un rôle capital pour décider si l'appareil répond aux attentes de manière satisfaisante. Il est essentiel de respecter les intervalles de maintenance prévus et d'effectuer avec soin les travaux d'entretien et de maintenance – cf. page 130 pp.

Le nombre d'heures de service actuel des pièces requérant une maintenance peut être affiché en mode de réglage préliminaire – cf. page 164 ff.

Les dispositifs de sécurité qui ont été déposés doivent être remontés après les travaux (p. ex. nattes filtrantes).



ATTENTION !

Employez uniquement des pièces détachées originales de même type ou compatibles ! L'emploi d'autres pièces annule la conformité ! Le constructeur décline toute responsabilité en cas de dommages résultant, preuves à l'appui, de l'utilisation de pièces détachées non originales.

Nettoyage

Surfaces en verre acrylique



ATTENTION !

Ne frottez pas les surfaces avec un chiffon sec – risque de rayures !

Pour un nettoyage rapide et hygiénique des surfaces en verre acrylique, utilisez exclusivement le produit de nettoyage et de désinfection rapide spécialement mis au point Antifect®. N'utilisez pas non plus d'autres produits de nettoyage non appropriés, en particulier des désinfectants concentrés ou des solvants (par ex. Lysoform, alcool éthylique ou autres liquides contenant de l'alcool) pour le nettoyage.

En cas de non-observation, les droits à la garantie ne sont plus reconnus.

Surfaces en plastique

Pour le nettoyage des autres surfaces en plastique, il est préconisé d'utiliser de l'eau tiède et une peau de chamois. N'utilisez jamais de détergents agressifs contenant de l'alcool (tel que le Sagrotan, produit disponible dans le commerce) ou des huiles essentielles. Ceci peut entraîner à long terme des dommages non couverts par la garantie.

Pendant le nettoyage, une légère décoloration de la peau de chamois due aux joints de caoutchouc doit être attendue pour des raisons relatives à la production.



Note :

Évitez l'endommagement des surfaces en verre acrylique et en plastique. Retirez bagues, montres, bracelets, etc., avant de procéder aux travaux de nettoyage.

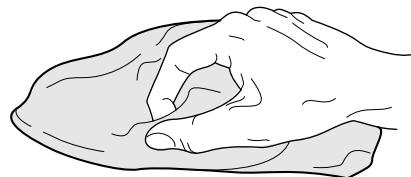
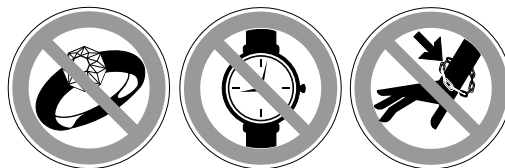

02756 / 0

Information relative à la protection de l'environnement

Déclaration relative à l'environnement – Le groupe d'entreprises JK

Le groupe d'entreprises JK se soumet aux règles strictes de la Directive CEE 761/2001 et de la norme DIN ISO\–14001 et fait l'objet de contrôles réguliers par des auditeurs professionnels portant sur la sécurité environnementale.

Réglementations relatives à l'environnement – évacuation des lampes

Les lampes UV basse et haute pression usagées contiennent un agent fluorescent et d'autres déchets contenant du mercure.

Selon les lois nationales sur l'évacuation des déchets et conformément aux règlements municipaux sur les déchets, les lampes UV doivent être mises au rebut correctement, preuves à l'appui.

Votre agence environnement locale est là pour vous assister en ce qui concerne la gestion des déchets de lampes UV.

Notice générale pour le bronzage

Quels peuvent être les utilisateurs ?

Toute personne qui peut bronzer à la lumière naturelle du soleil. Les personnes à peau sensible peuvent même bronzer plus en douceur et sans soucis, étant donné que les solariums permettent un dosage exact des rayons.

Certains médicaments – en particulier ceux produisant une photosensibilité – peuvent provoquer, chez les personnes les utilisant, des effets contraires ; ces personnes doivent éviter de s'exposer à des sources UV de toutes natures. Les médecins aviseront les personnes prenant ces médicaments de leurs effets contraires.

La rapidité et l'intensité du bronzage dépendent du type de peau et de la concentration de mélanine individuelle dans la peau. Il n'y a pas deux teintes de peau identiques. Le bronzage d'une personne peut varier d'une personne à l'autre, au même titre que la durée du traitement.

Qu'est-ce que la mélanine ?

La pigmentation brunâtre produite par certaines cellules de la couche inférieure de notre peau détermine le bronzage individuel. Quand la peau est exposée à la lumière ultraviolette, la mélanine est activée et se combine à des cellules de protéine qui se déplacent vers la surface de la peau, produisant le bronzage. La quantité de mélanine dans la peau détermine la rapidité et l'intensité du bronzage. Plus la peau produit de mélanine, plus le bronzage sera rapide et intensif, suivant la durée d'exposition.

**Note :**

Le bronzage réalisé par l'appareil est un bronzage « cosmétique » profond et durable. Toutefois et indépendamment de l'intensité de bronzage à laquelle une personne peut être soumise avec cet appareil, il ne fournit pas de protection adéquate contre la surexposition aux rayons du soleil ou aux systèmes de bronzage UVB.

Quelles durées de bronzage sont-elles recommandées ?

Bien qu'il n'y ait aucune raison de se soucier des coups de soleil avec la méthode de bronzage aux UV, certaines indications de base doivent être fournies selon la sensibilité de la peau des différentes personnes.

**Risques de blessures et de maladies de la peau !**

DANGER ! Bien que les rayons UVA soient relativement inoffensifs comparativement aux rayons naturels du soleil, des durées de bronzage excessives peuvent entraîner des rougeurs et des brûlures de la peau.

- Observez les durées de bronzage recommandées, cf. page 93.

Une fois que vous avez votre bronzage, 1 ou 2 séances de bronzage par semaine sont normalement suffisantes pour le conserver.

Devez-vous utiliser une crème solaire ?

Non ! Il est recommandé de ne pas utiliser de crèmes solaires, d'huiles ou de lotions prévues pour l'extérieur. Les crèmes solaires cosmétiques avec facteur de protection (SPF) sont prévues pour filtrer les rayons

agressifs du soleil. Toutefois, la lumière de nos solariums ne contient que de très petites quantités de rayons comparables, ce qui rend inutile l'emploi de ce genre de protection. Au contraire, la peau doit être parfaitement propre et sèche avant chaque bain de soleil. Des nombreux maquillages pour visage contiennent des huiles et doivent être enlevés avant une séance.

Une ventilation appropriée de la pièce ou de la cabine du solarium est requise pour une utilisation correcte et confortable. Votre solarium fonctionnera le mieux à une température ambiante de 24 °C à 32 °C.

Après une séance de bronzage, il est recommandé d'appliquer une lotion hydratante sur la peau. Ceci donne un bronzage plus doux et plus agréable à regarder.

Types de peau

Pour le plan d'exposition recommandé (cf. page 93):

Type de peau II :

C'est le type de personne facilement et fortement sujet aux brûlures, qui bronze de façon minimale ou légère et qui pèle.

Type de peau III :

Souvent désigné par teint « moyen », brûlures modérées et bronzage moyen.

Type de peau IV :

Brûlures minimales, bronzage aisé et au-dessus de la moyenne à chaque exposition.

Type de peau V :

Ce genre de personne n'est sujet que rarement à des brûlures, bronzant aisément et en profondeur.

Service

Lecture impérative

Lisez et suivez toujours les instructions d'utilisation appropriée avant d'utiliser un solarium. Les instructions de service accompagnant l'appareil doivent toujours être suivies pour éviter les blessures possibles ou pour les minimiser.

Informez les utilisateurs

- pour qu'ils utilisent des lunettes de protection neutralisant les UV quand l'équipement est sous tension
- pour qu'ils respectent le plan d'exposition selon leur type de peau. La non-observation est la cause de surexposition.

Un solarium n'est pas un jouet. Vous ne pouvez pas modifier la puissance des lampes dans votre appareil.

Si vous avez des questions relatives à l'utilisation correcte de votre solarium, contactez SUN Ergoline au :

☎ 1-800-643-0086

de 8.00 à 17:00 heures (CST)



AVERT. !

Avertissement – rayons ultraviolets !

Risques de blessures et de maladies de la peau !

- Le solarium ne doit jamais être utilisé quand un panneau filtrant manque ou est endommagé, ou quand la minuterie est défectueuse.



Note :

Pour décrire les opérations, le solarium est représenté avec la partie supérieure ouverte. Pendant la séance de bronzage, la partie supérieure doit toujours être fermée.

Un service correct n'est pas possible quand la partie supérieure est ouverte.

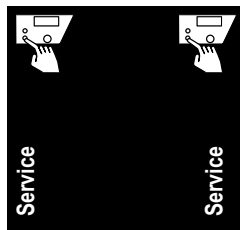

Ouvrir la partie rabattable.

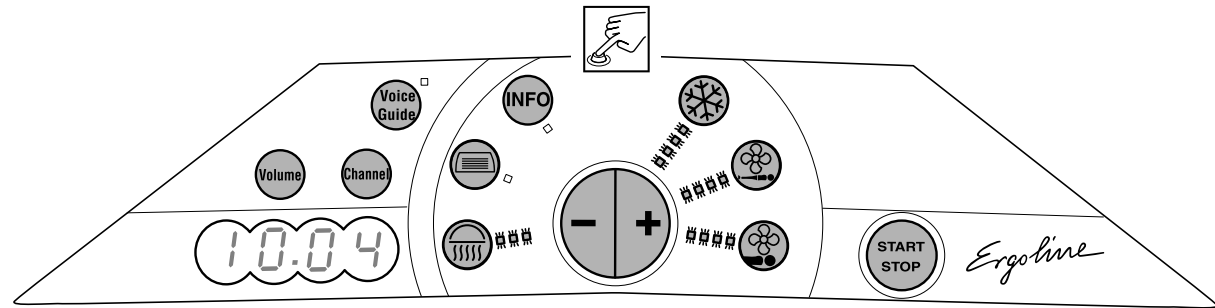

04906 / 0

F

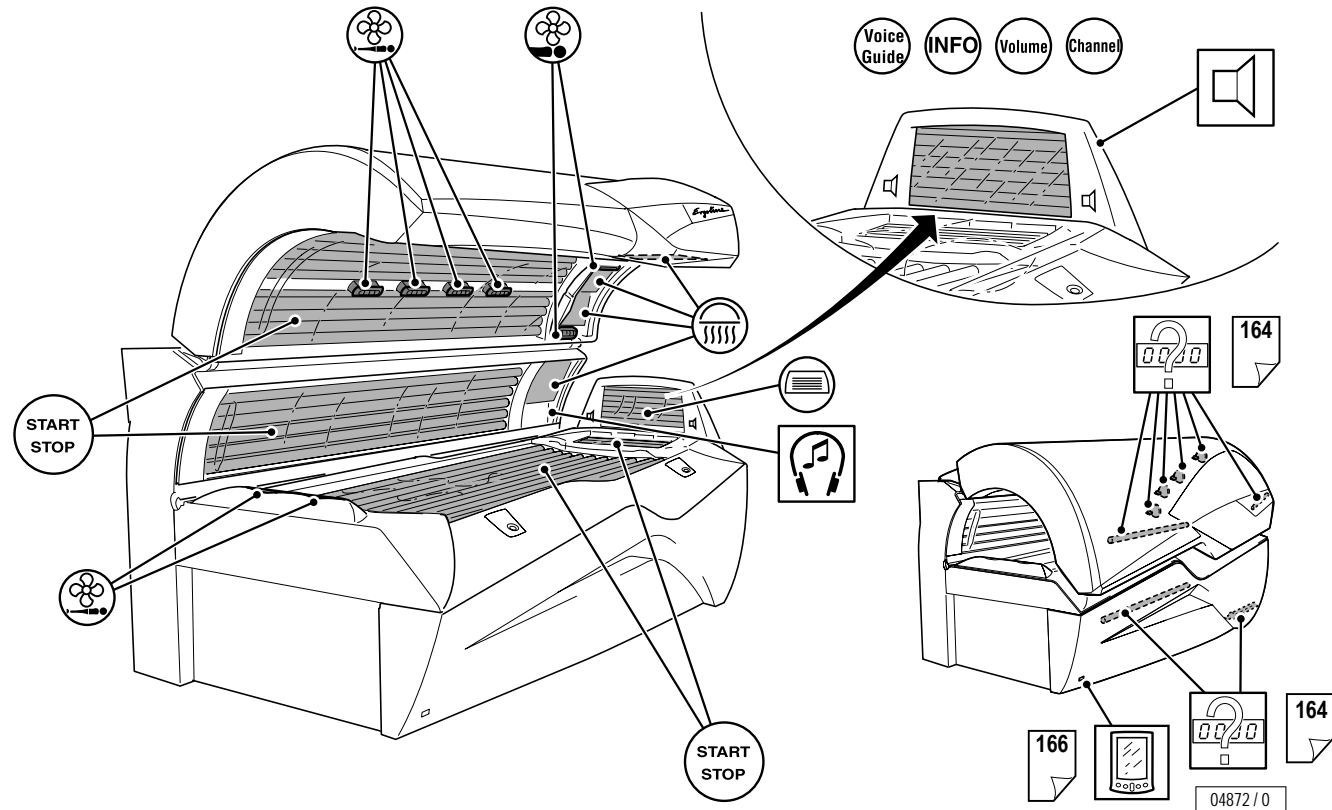
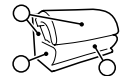

04872 / 0

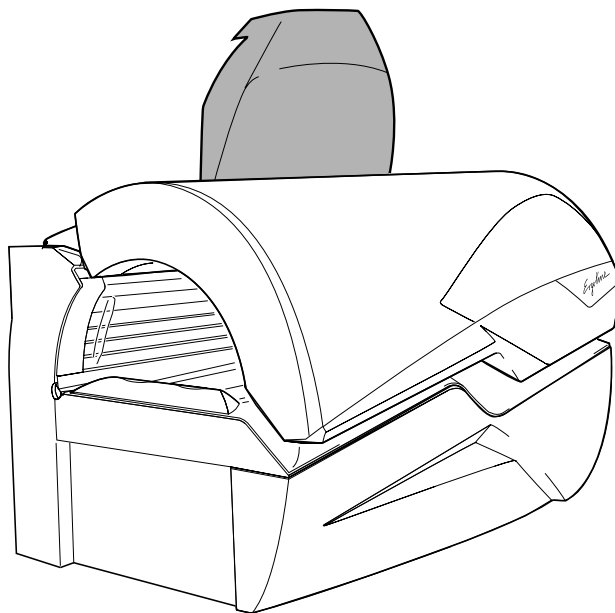
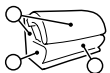

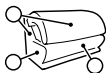

Bronzage

Début et fin de la séance de bronzage

L'appareil démarre automatiquement avec une minuterie interne ou externe et s'arrête automatiquement une fois la durée présélectionnée écoulée. Le ventilateur continue à fonctionner pendant env. 3 minutes (poursuite) afin de refroidir correctement l'appareil.



Note :

Instructions sur la minuterie : cf. manuel séparé.

Temps de préparation

Avant que les lampes UV s'allument automatiquement, vous avez quelques minutes pour vous préparer. Pendant la préparation, vous pouvez allumer à tout moment les lampes UV en appuyant sur le bouton START/STOP.

- Enlevez vos vêtements et tous vos bijoux.
- Nettoyez maquillage et cosmétiques.
- Retirez vos lunettes. Vous pouvez conserver vos verres de contact sous les lunettes de protection.
- Mettez les lunettes de protection.
- Allongez-vous sur la banquette.
- Fermez la partie supérieure.

Selon le contrôleur, le solarium démarre automatiquement peu de temps après. Le solarium fonctionne quand les lampes UV sont allumées et quand les ventilateurs tournent.

Si l'appareil ne démarre pas une fois que vous avez fermé la partie supérieure :

- appuyez sur START/STOP pour démarrer la séance de bronzage.

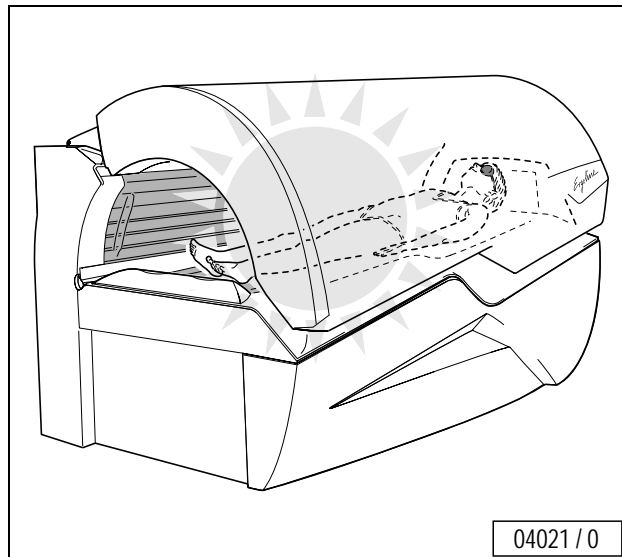

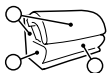

Réglages pendant le démarrage

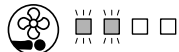
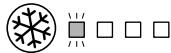
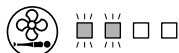
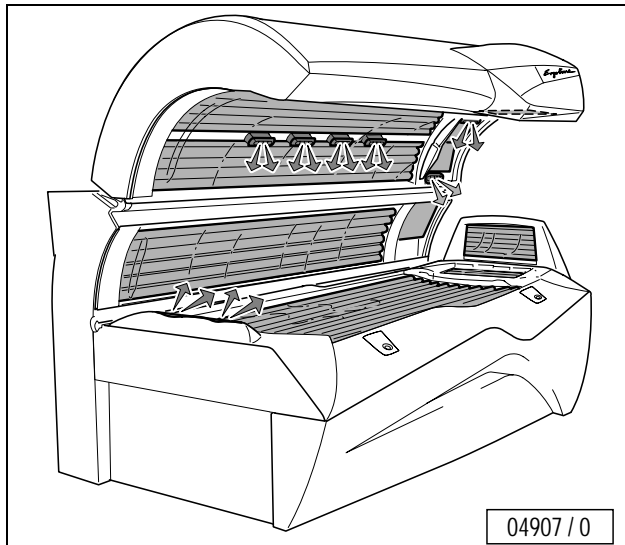

Pour interrompre la séance de bronzage

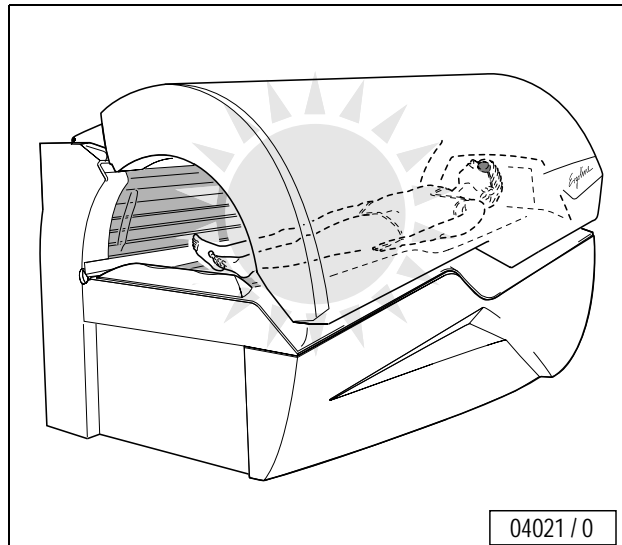

La séance peut être interrompue pendant le bronzage en éteignant les lampes UV :

- Appuyez sur START/STOP pendant trois (3) secondes pour suspendre ou stopper le bronzage.
- Appuyez à nouveau sur START/STOP pendant trois (3) secondes pour rallumer les lampes.



Service





Durée de fonctionnement des lampes décoratives

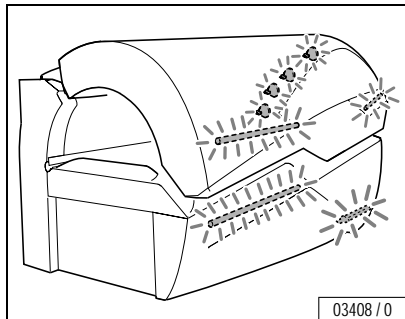

03408 / 0

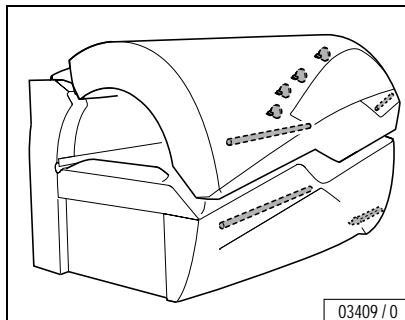
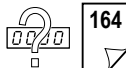

03409 / 0

Les lampes décoratives sont allumées pendant et après la séance de bronzage et s'éteignent automatiquement à la fin de la durée présélectionnée.

La durée de fonctionnement des lampes décoratives en mode veille peut être modifiée lors des préréglages – cf. page 164.

Fonction IR

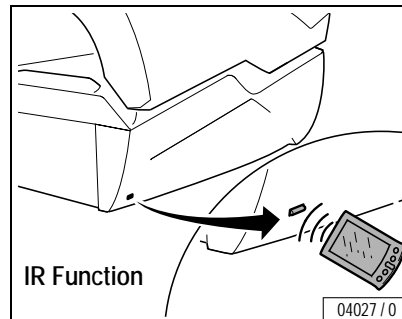
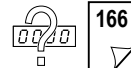

04027 / 0





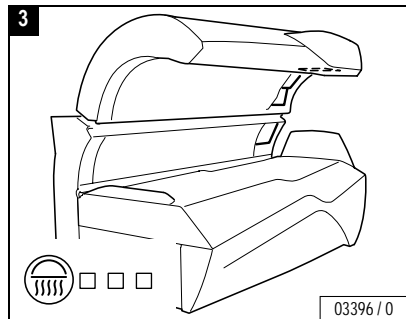
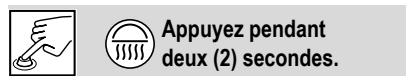
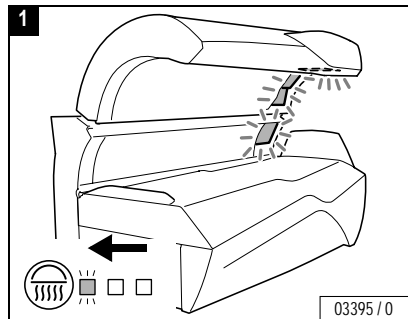
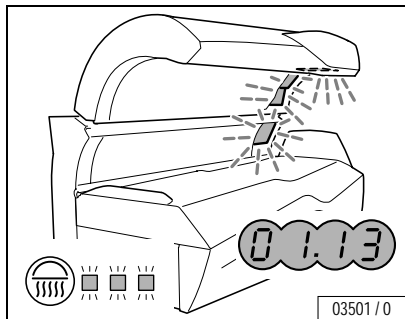

Bronzeurs faciaux



Extinction des bronzeurs faciaux (OFF) :

- Appuyez sur le bouton  pendant deux (2) secondes.

Rallumage des bronzeurs faciaux :

- Appuyez à nouveau sur le bouton . Les bronzeurs faciaux parviennent à leur plein rendement au bout d'environ une (1) minute.

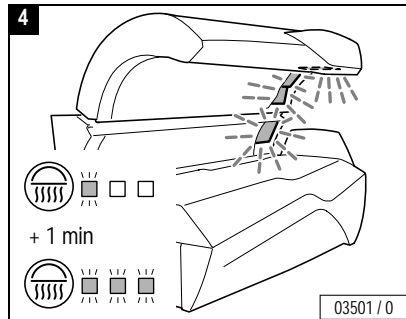
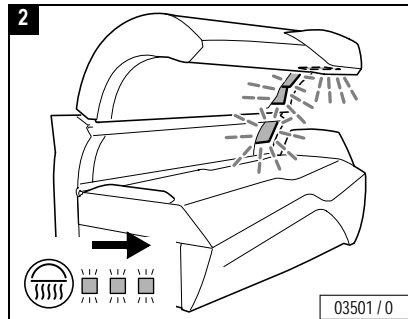

Service



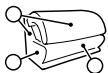

Bronzeur pour épaules

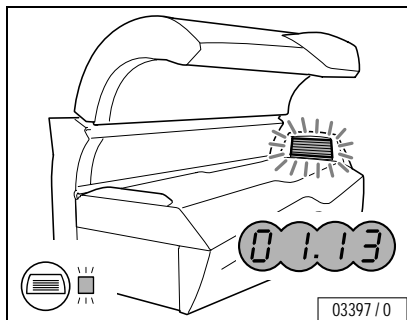

Appuyez pendant deux (2) secondes.

1

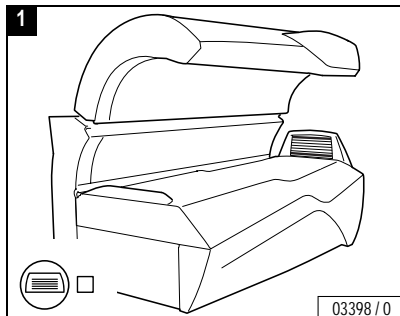

2

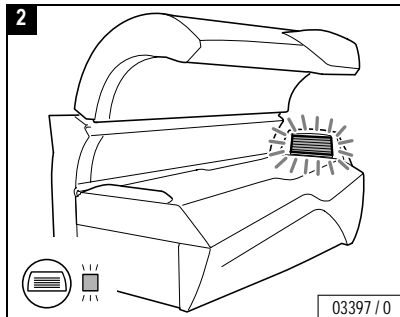

Extinction du bronzeur pour épaules (OFF) :

- Appuyez sur le bouton  pendant deux (2) secondes

Rallumage du bronzeur pour épaules :

- Appuyez à nouveau sur le bouton .



Service





Temptronic – Réglage de la fraîcheur

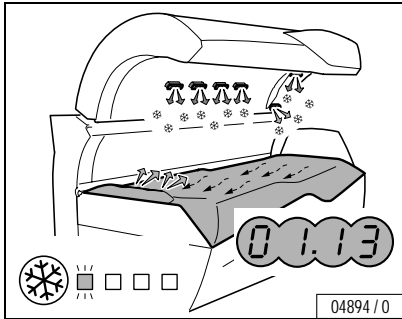

Pendant le démarrage, le second de 8 niveaux est actif.

- Appuyez sur le bouton  (Temptronic).
- Quand le bouton clignote, appuyez sur le bouton plus ou moins pour modifier l'intensité du refroidissement.

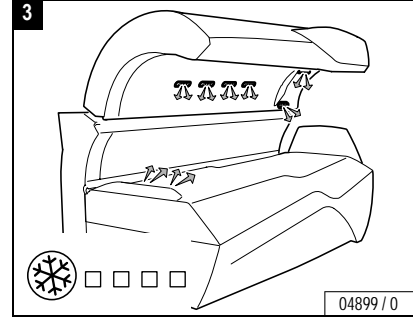
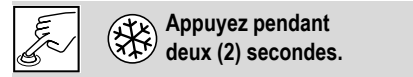
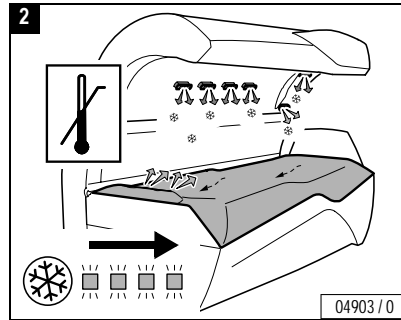
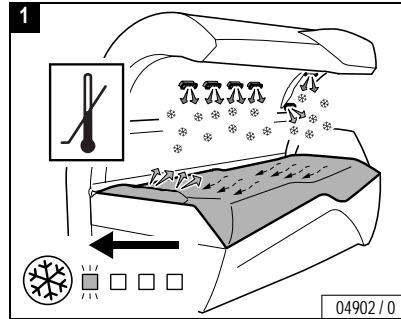



Service



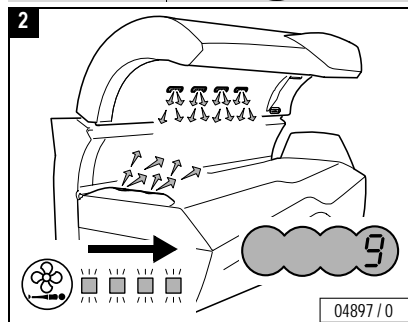
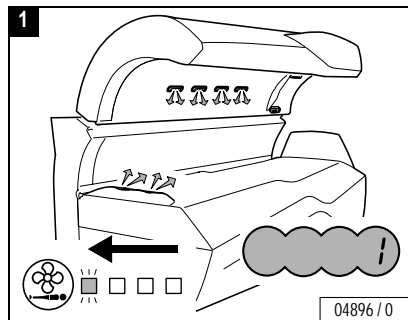
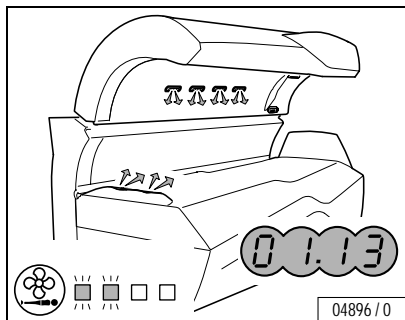

Tuyères de ventilation corporelle intégrale – réglage de la vitesse



- Appuyez sur le bouton .
- Quand le bouton clignote, appuyez sur le bouton plus ou moins pour modifier l'intensité du flux d'air.





Tuyères de rafraîchissement de visage intégral – réglage de la vitesse

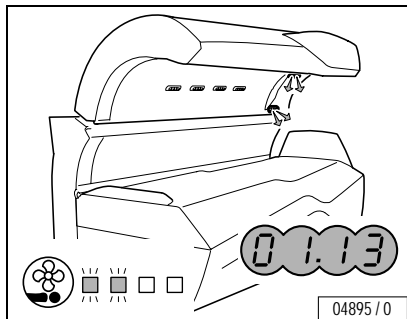

04895 / 0

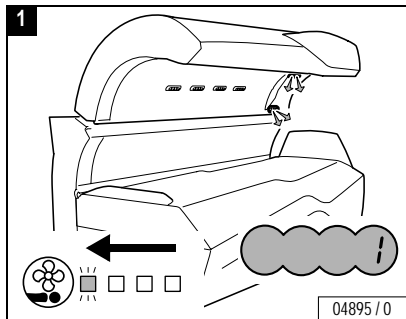

04895 / 0

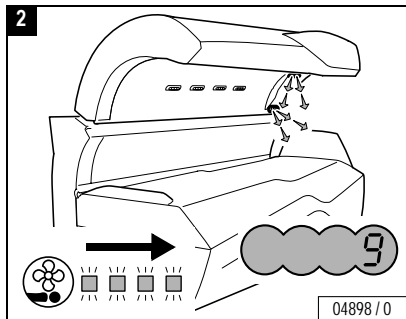

04898 / 0

- Appuyez sur le bouton .
- Quand le bouton clignote, appuyez sur le bouton plus ou moins pour modifier l'intensité du flux d'air.



Service



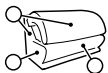

Voice Guide

Service

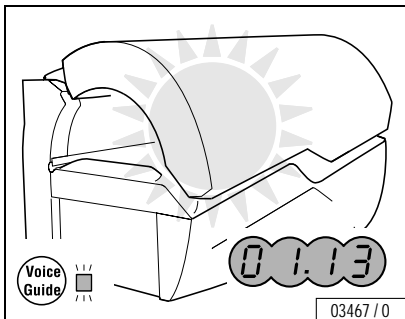

Quand le système Voice Guide est en service, vous entendez une explication de la fonction du bouton à chaque fois que vous appuyez dessus.



Voice Guide

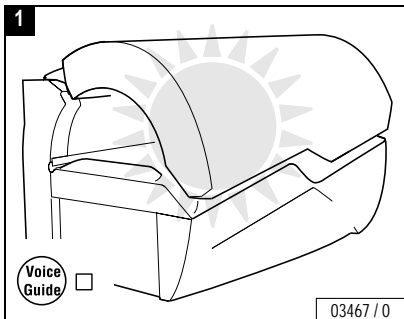

Voice Guide

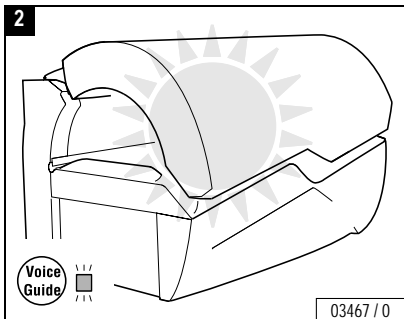

Voice Guide



- ...
- ...
- ...
- ...
- ...
- ...
- ...
- ...
- ...



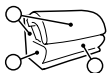

INFO

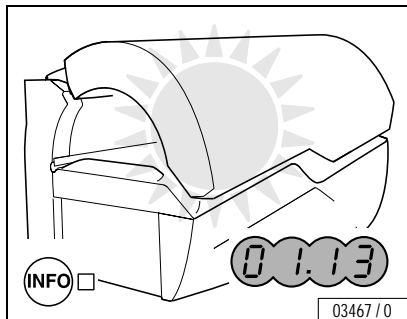

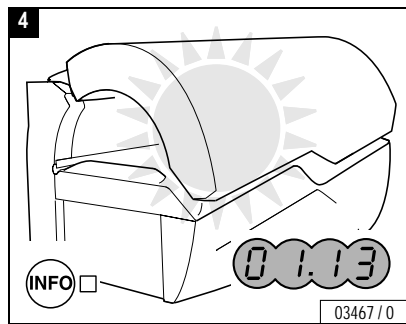
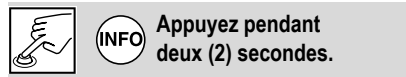
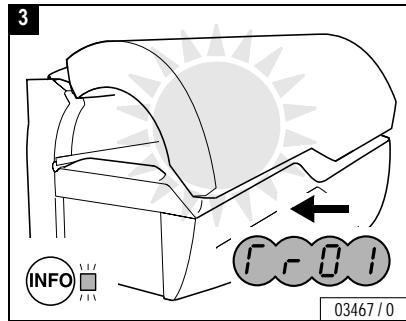
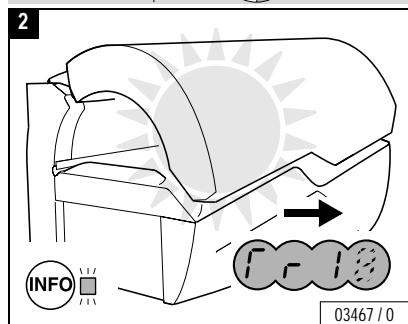
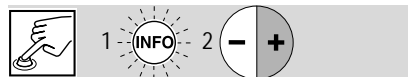
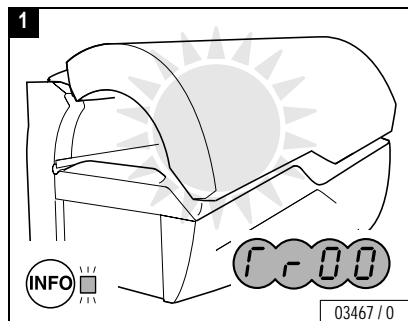

Quand vous appuyez sur le bouton **INFO**, des textes généraux sur le bronzage sont parlés.

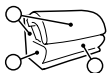

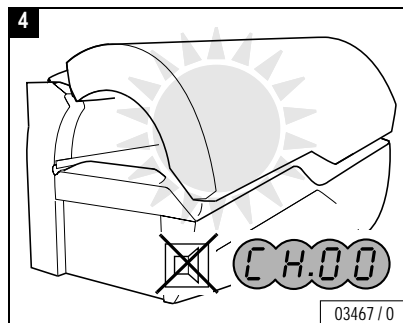
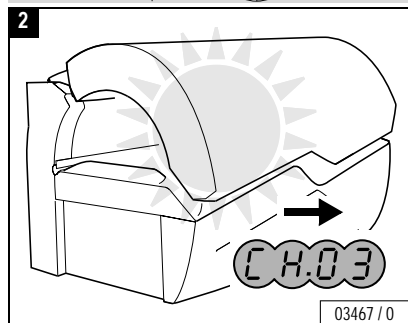
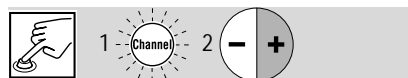
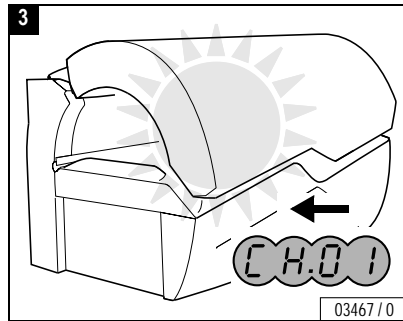
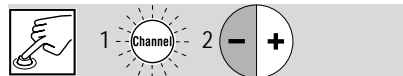
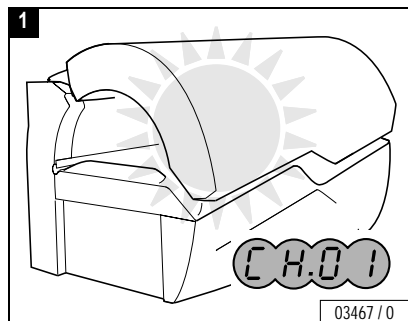
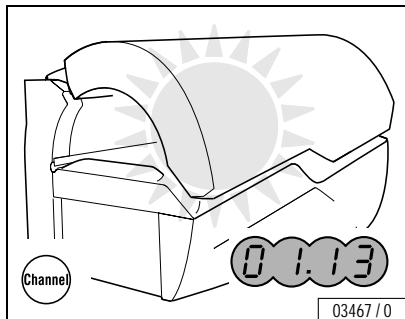

Channel



– Appuyez sur le bouton .

– Quand le bouton clignote, appuyez sur le bouton plus ou moins pour sélectionner un canal.

CH.00 autrement dit : aucun canal sélectionné, aucun son ; la musique est arrêtée (« OFF »).



Volume

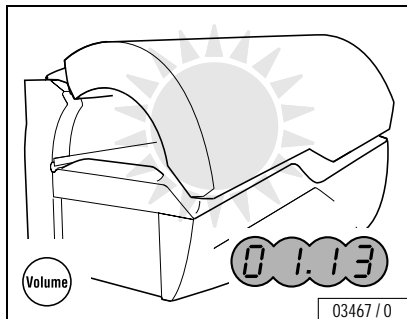

- Appuyez sur le bouton .
- Quand le bouton clignote, appuyez sur le bouton plus ou moins pour modifier le volume.

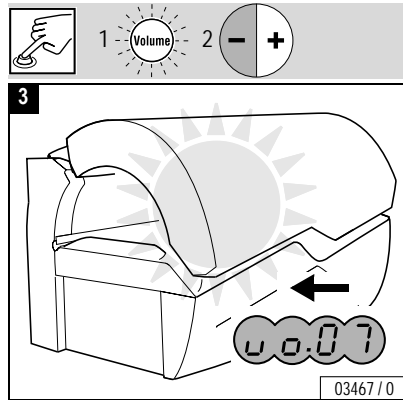
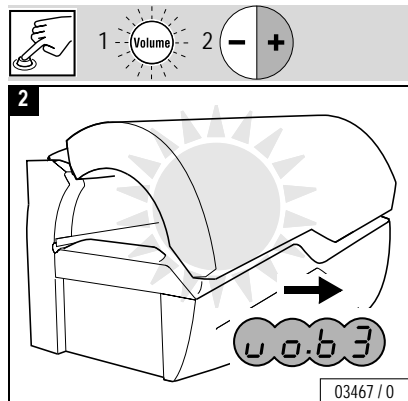
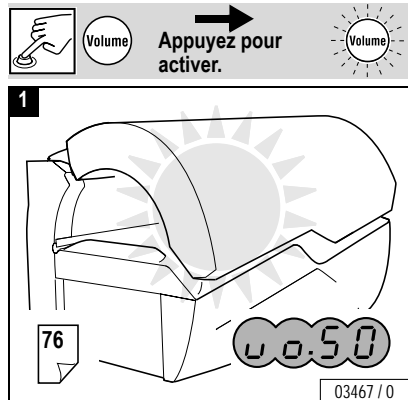



Caractéristiques techniques

Type d'appareil :	Ergoline Excellence 800 Turbo Power
Puissance nominale :	13900 W 17000 W
Tension nominale :	230 V
Fréquence nominale :	60 Hz
Pouvoir de coupure nominal :	50 amp 3 pôles 80 amp 2 pôles
Marque de contrôle :	

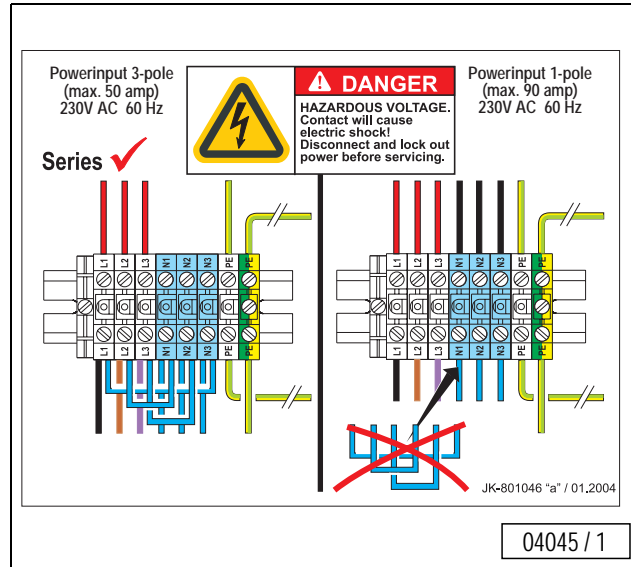



Tolérance solarium dans la pièce

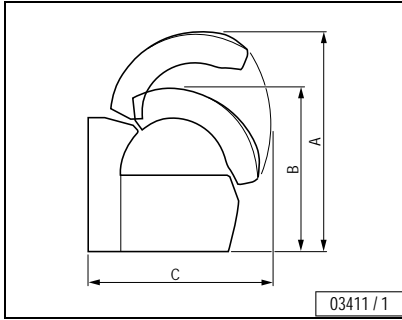

03411 / 1

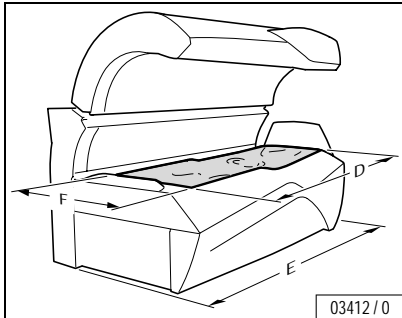

03412 / 0

A = 1830 mm	A = 72 1/16 in
B = 1373 mm	B = 54 1/16 in
C = 1510 mm	C = 59 7/16 in
D = 2110 mm	D = 83 1/16 in
E = 2323 mm	E = 91 7/16 in
F = 850 mm	F = 33 7/16 in

Température / humidité ambiantes maximum

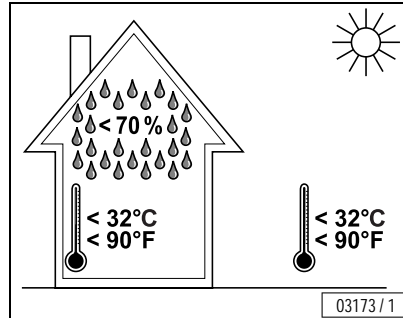

03173 / 1

Charge maximale autorisée

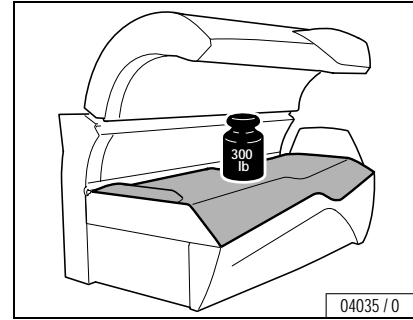

04035 / 0



AVERT. !

Avertissement – bris possible du panneau acrylique !

De graves coupures par le verre et brûlures par les lampes chaudes peuvent en résulter !

- Une seule personne adulte à la fois est autorisée.
- Les personnes d'un poids supérieur à 300 lb (150 kilos) ne doivent en aucun cas utiliser l'appareil.



Caractéristiques tech.



F

F



Maintenance

Couper la tension sur l'appareil et verrouiller contre la remise en marche



DANGER !

Danger de mort !

Si des travaux doivent être exécutés sur les appareils, ils doivent être mis hors tension. Ceci signifie que les cinq lignes actives doivent être mises hors tension.

La mise hors tension seule de l'appareil ne suffit pas, car certains points peuvent demeurer sous tension. Il convient donc de désactiver les fusibles avant de procéder à des travaux et de les retirer, si cela est possible.



04049 / 0

- Quand des coupe-circuits ne peuvent pas être dévissés, un ruban adhésif doit être appliqué sur la manette d'actionnement, portant la mention « Ne pas activer – danger ! ».

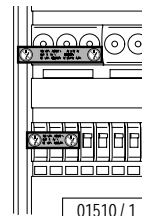

01510 / 1

Installer systématiquement dès le début des travaux un panneau d'interdiction sur lequel figure l'inscription :

- « Travaux en cours ! »
- « Localisation : »
- « Le panneau ne peut être enlevé que par : ».



01511 / 1



DANGER !

Danger de mort !

Les panneaux d'interdiction ne doivent pas être accrochés à des pièces sous tension ni les toucher.

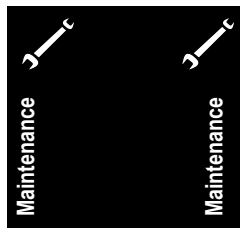

Ouvrir la partie rabattable.

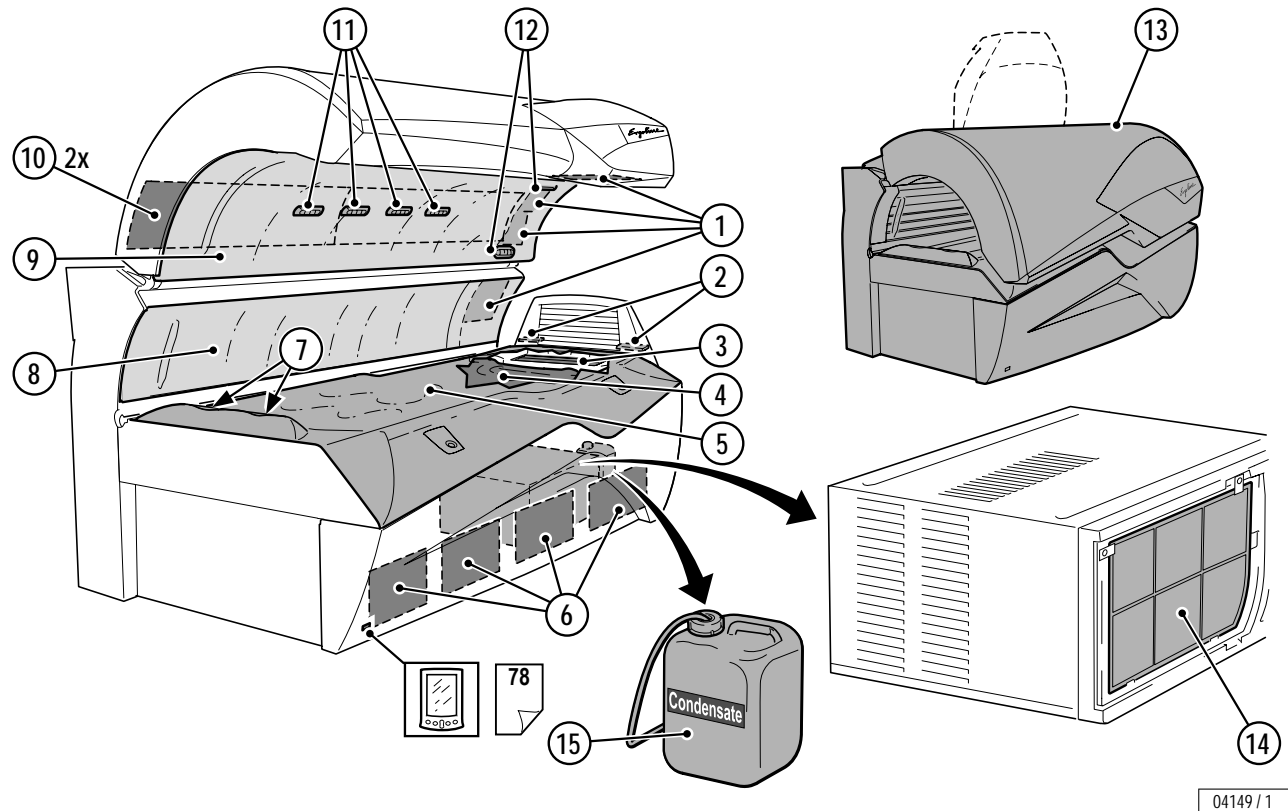
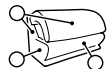

F



Nettoyage planifié

	⑤	<p>Note: Nettoyer après chaque utilisation.</p>	



Danger – Risque d'irritation des yeux !
 Pour nettoyer les lunettes de protection, utilisez exclusivement un désinfectant approprié.



Nettoyage planifié

F

	① - ⑬	⑮	
Nettoyer si nécessaire !	⑬		
	④		

Maintenance

F**Maintenance planifiée – filtres**







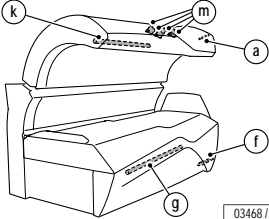

/50 h	⑥ 4 x			51937		157
	⑩ 2 x			800601		159
	⑭ 1 x			51975		162
	② 2 x			800278		160

**Maintenance**



Maintenance planifiée – éclairage de décoration

F

	Excellence 800 Turbo Power VHP 12			
	 a) 1 x  blanc 8 W f) 1 x  bleu 9 W 1 x  rouge g) 1 x  bleu 30 W 1 x  rouge k) 1 x  bleu 30 W m) 4 x  _____ 12 V 1 x _____ rouge 1 x _____ jaune 1 x _____ bleu 1 x _____ rosa 1 x _____ orange a) g) 3 x  S10 k)		11839	152
			12262	155
			12458	
			12377	155
			12459	
			12263	144
				152
			701830	
			701826	
			701827	
701829				
701831				
10047				





Maintenance planifiée – lampes à décharge, starters

Maintenance

	Excellence 800 Turbo Power VHP 12			
500 h				131 146, 149 135 141 142 137 139
1000 h				131 146, 149 135 141 142 137 139 10012 10047



Les lampes UV haute pression utilisées, JK Ergoline 500 SE C11292 (bronzeur facial), sont des éléments de chauffage à large bande pouvant fonctionner à des puissances diverses (approx. 240-520 W).



Lampes à décharge UV basse pression : nettoyer à l'eau claire (par ex. à l'aide d'un chiffon humide).



1500 h	⑤		700624	135	
3000 h	④		800399	135	
	③		800389	137	
	① (ViT)		704288	146, 149	



Panneaux filtrants : nettoyer à l'eau claire (par ex. à l'aide d'un chiffon humide).



Instructions relatives au remplacement des lampes / maintenance

En tant qu'exploitant et/ou opérateur, vous devez impérativement vérifier tous les composants pour vous assurer qu'ils ne comportent pas de signes d'usure susceptibles de se produire en service normal.

- Observez le plan de nettoyage et de maintenance spécifié dans le tableau de maintenance à la page 128 to 133.
- Ne remplacez pas la lampe UV basse pression que par des lampes originales de même type ou des lampes compatibles.
- Ne remplacez pas la lampe UV haute pression que par des lampes originales de même type ou des lampes compatibles.

Si vous avez besoin d'assistance ou d'informations supplémentaires, veuillez contacter la Global Service Division au 1-800-445-0624, du lundi au vendredi, de 8:00 à 19:00 heures (CST).



ATTENTION – Dommages dus à une maintenance incorrecte !

Une maintenance incorrecte peut être la cause d'endommagements de l'appareil, le rendant inutilisable.

- Observez toujours les intervalles de maintenance spécifiés.
- Suivez les instructions de nettoyage.
- Si les intervalles de maintenance des lampes UV sont dépassés ou si des lampes UV incompatibles sont installées, le pourcentage de rayons UVB nocifs peut augmenter. Des coups de soleil ou autres endommagements de la peau peuvent en résulter !



Danger de brûlures dû aux lampes et pièces de machines chaudes

AVERT. !

Quand le solarium fonctionnait avant la mise hors tension et l'ouverture, ses lampes et ses pièces peuvent être chaudes.

- Avant de remplacer les lampes ou d'autres pièces détachées, attendez que les lampes et les pièces métalliques soient suffisamment refroidies.



Danger de pincement !

Quand vous ouvrez et fermez le bac, les panneaux et les recouvrements, vous pouvez vous pincer les doigts.

- Évitez les charnières.





Partie inférieure, lampes à décharge UV basse pression

F

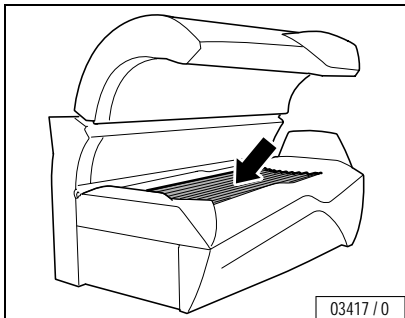
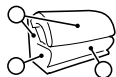

03417 / 0



Mettez l'appareil hors tension !

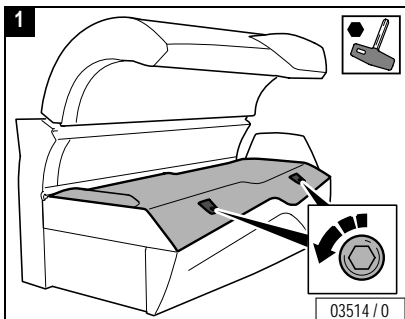

03514 / 0

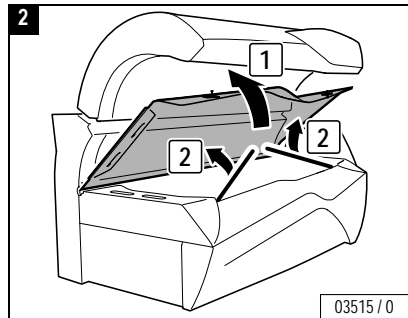

03515 / 0

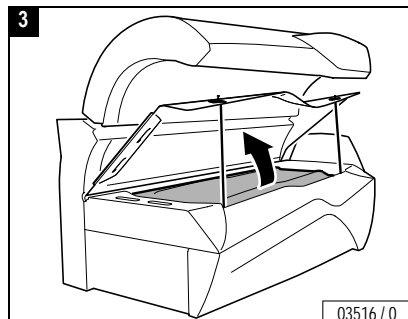

03516 / 0

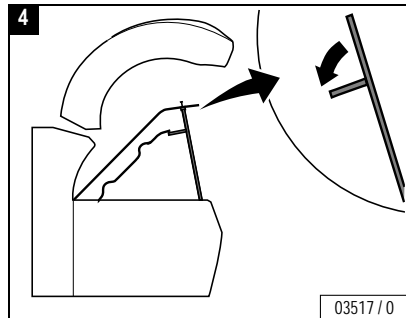

03517 / 0

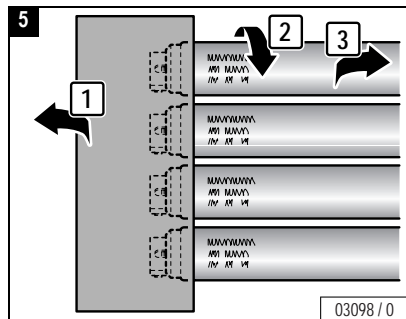

03098 / 0

Maintenance

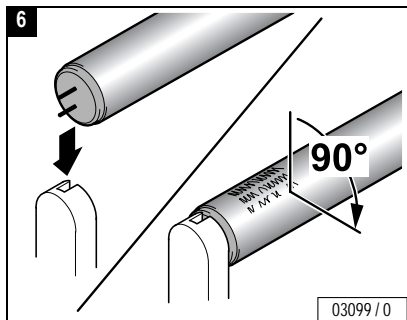

Fermer :

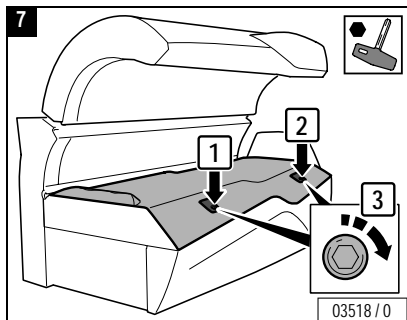



Bronzeurs pour nuque, lampes à décharge UV basse pression

F

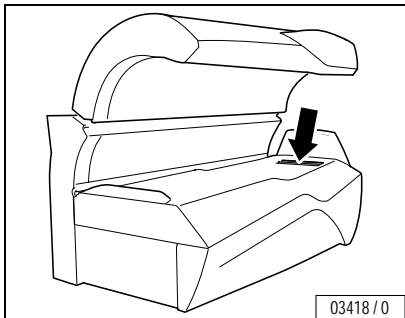
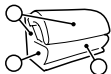

03418 / 0

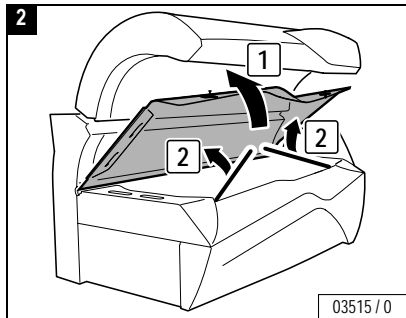

03515 / 0

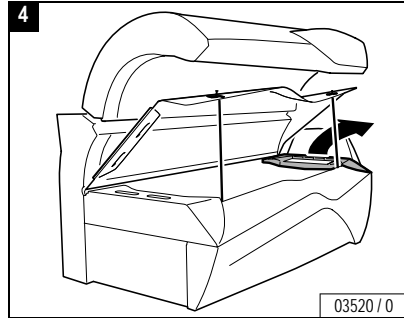

03520 / 0



Mettez l'appareil hors tension !

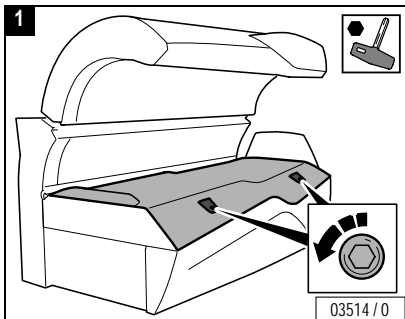

03514 / 0

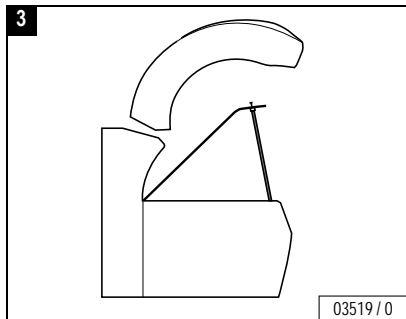

03519 / 0

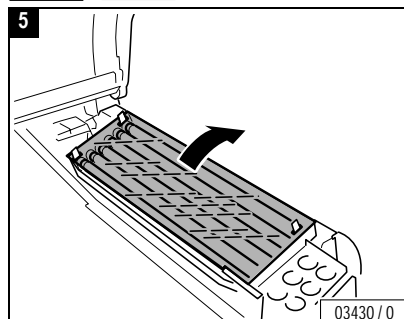

03430 / 0

Maintenance

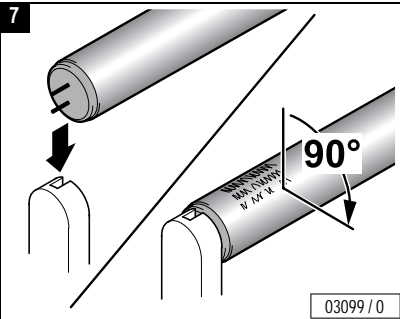
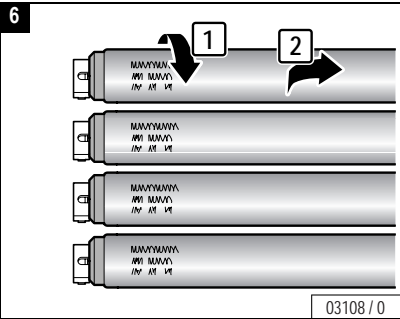

Fermer :

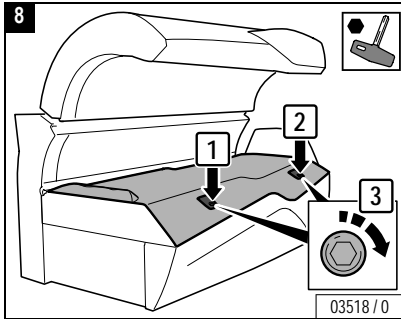

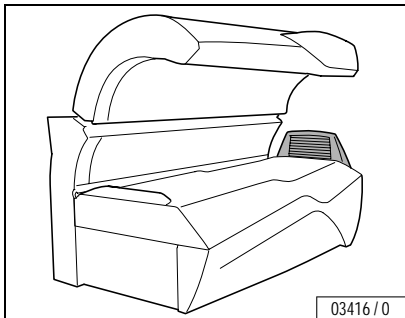
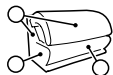

03416 / 0

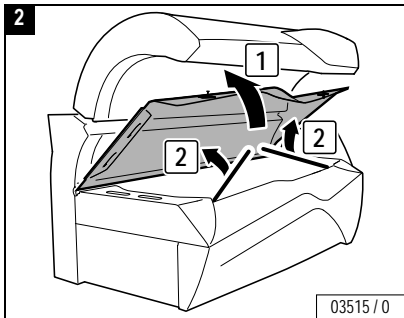

03515 / 0

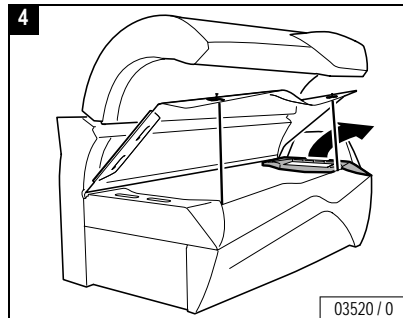

03520 / 0



Mettez l'appareil hors tension !

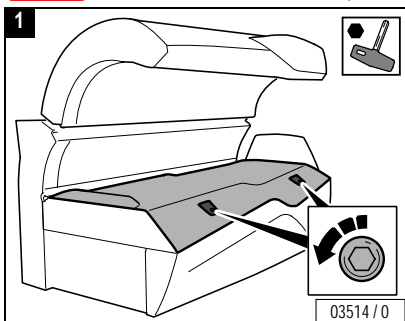

03514 / 0

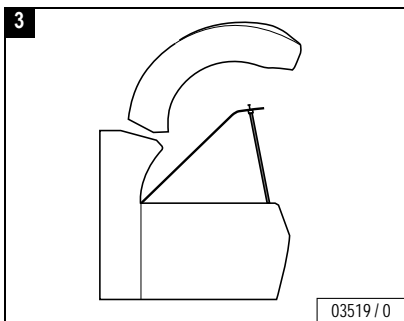

03519 / 0

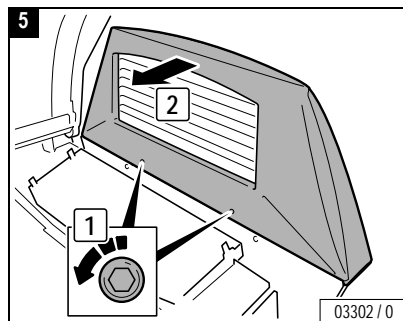

03302 / 0

Maintenance 

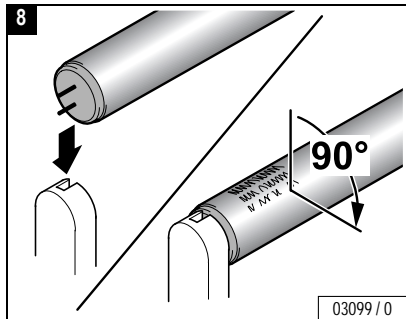
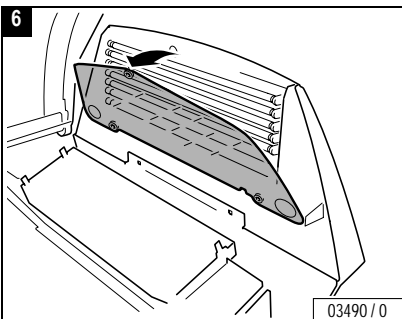

Fermer :

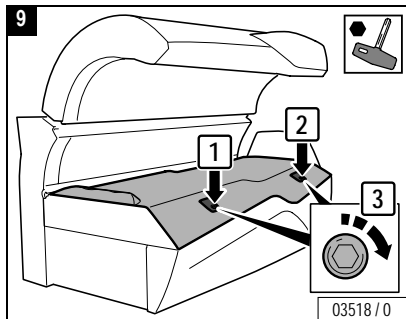
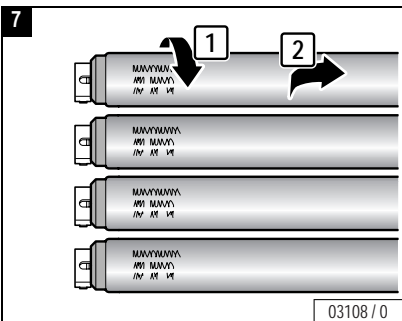

Maintenance





Partie latérale, lampes à décharge UV basse pression

F

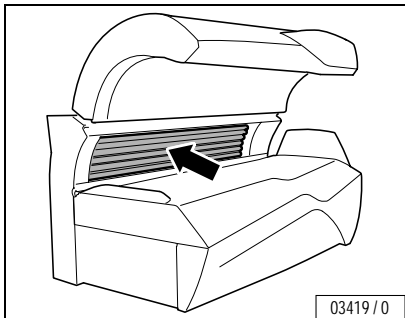
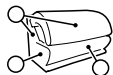

03419 / 0

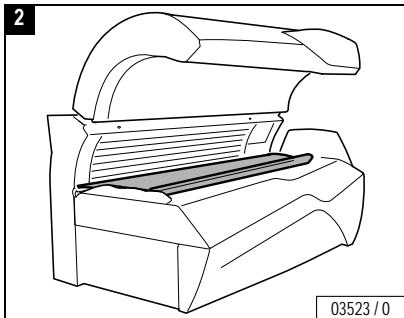

03523 / 0

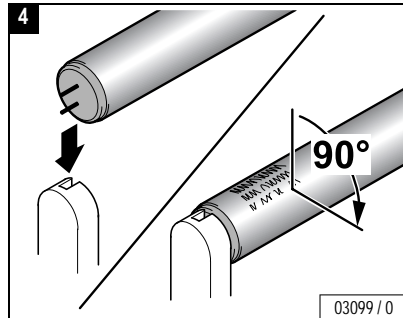

03099 / 0



Mettez l'appareil hors tension !

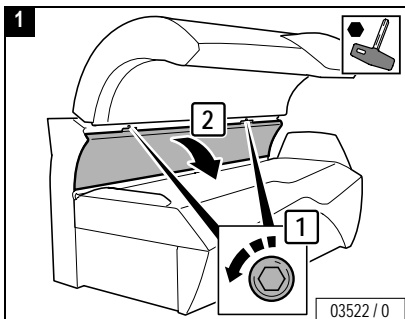

03522 / 0

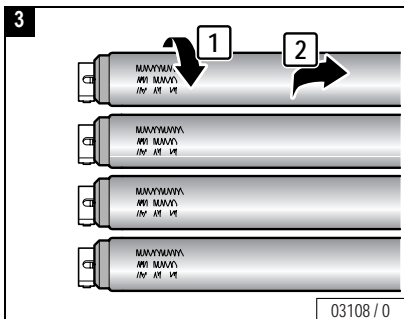

03108 / 0

Fermer :

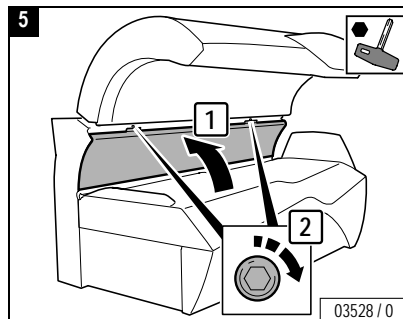

03528 / 0

Maintenance



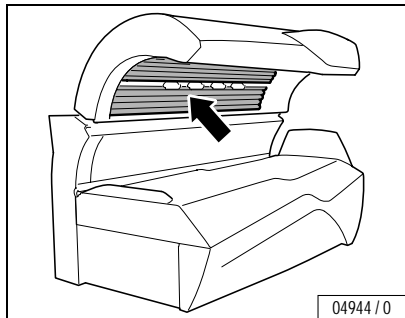
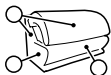

**Mettez l'appareil
hors tension !**

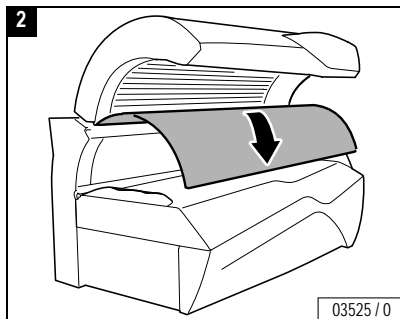
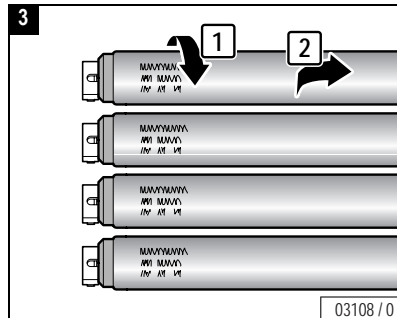
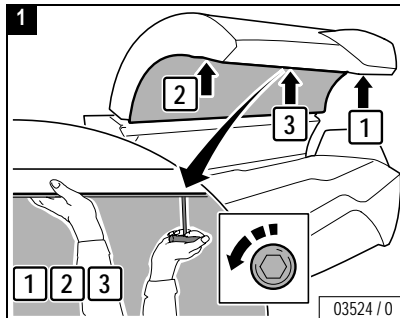

**Danger de blessures par la
partie supérieure !**

Avert. !

La partie supérieure est lourde et
tombe d'elle-même quand les
3 vis sont desserrées.

- Etayez la partie supérieure.
- Desserrez les vis dans l'ordre
indiqué.



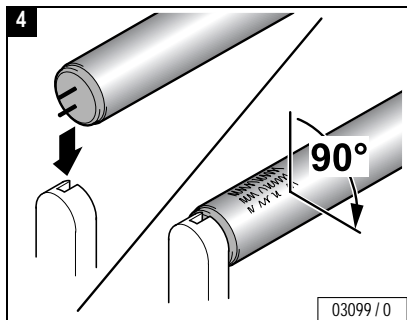

Fermer :

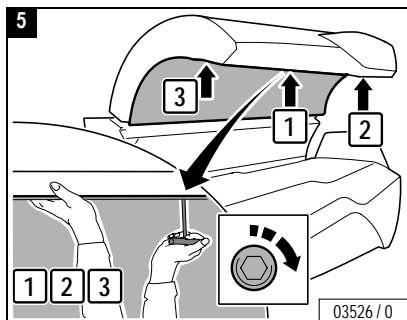

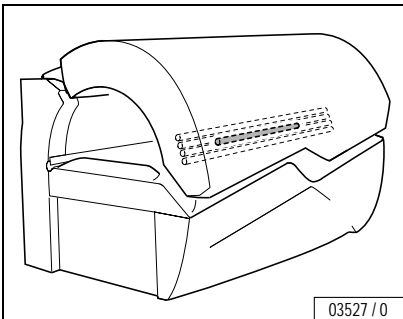
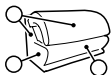

Mettez l'appareil hors tension !

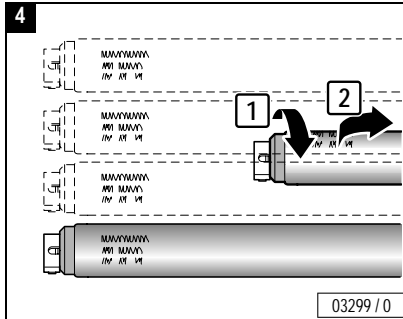
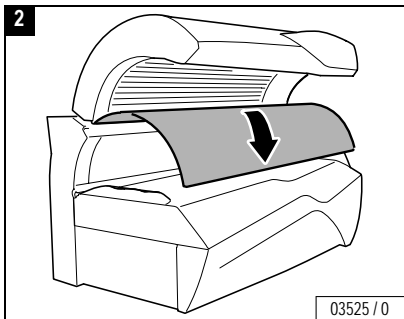
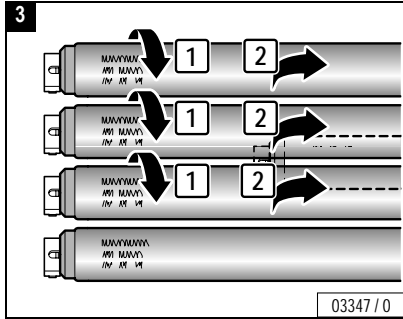
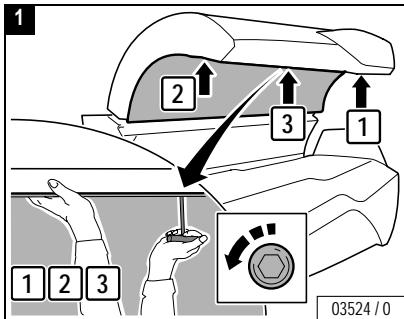

Maintenance



Danger de blessures par la partie supérieure !

Avert. !

La partie supérieure est lourde et tombe d'elle-même quand les 3 vis sont desserrées.

- Etayez la partie supérieure.
- Desserrez les vis dans l'ordre indiqué.

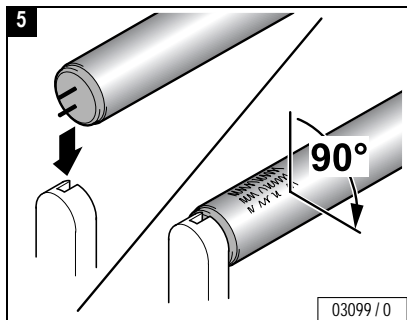

Fermer :

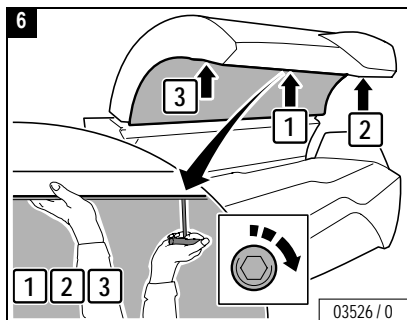

Maintenance 





Partie latérale, lampes à décharge UV haute pression

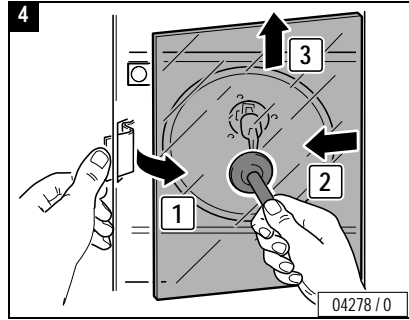
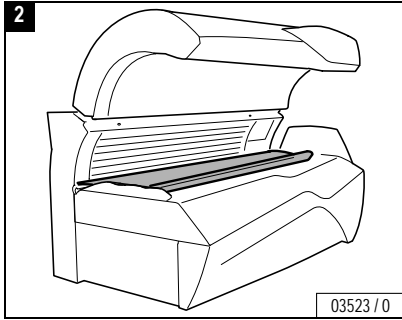
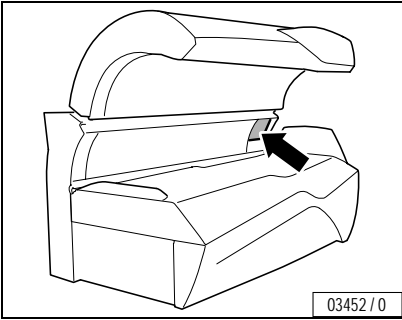
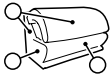

Maintenance



Mettez l'appareil hors tension !

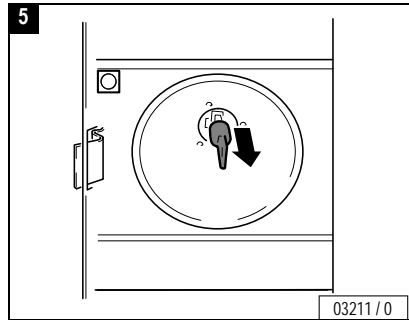
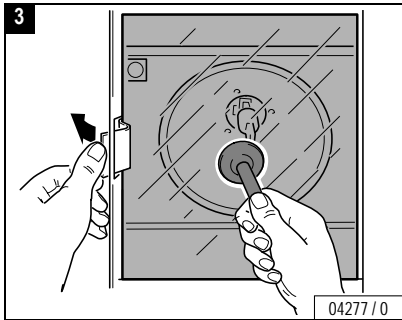
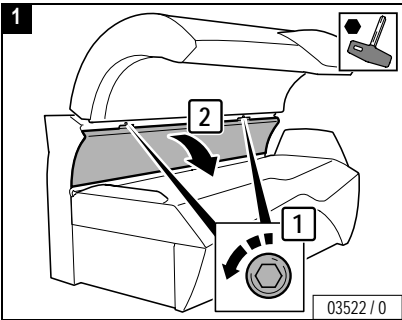

...

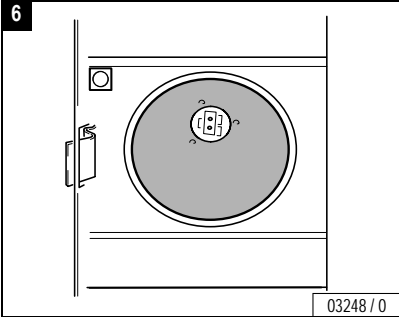

ATTENTION !
 Ne touchez pas aux ampoules de verre des lampes UV haute pression avec les doigts nus ! Enlevez soigneusement les salissures.

- Ne touchez la nouvelle lampe UV haute pression que sur la surface de saisie - cf. figures 7 et 8.

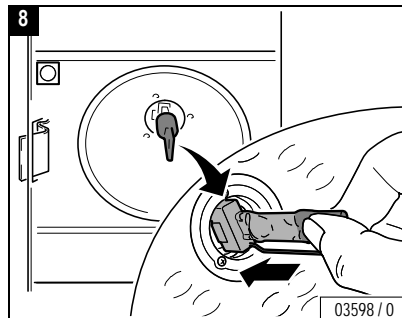
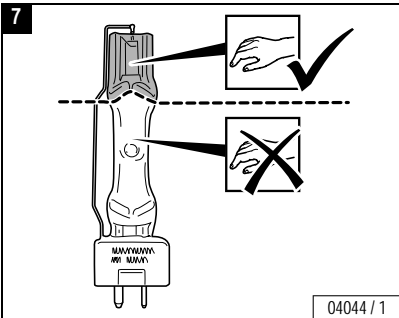

- Vérifiez l'interrupteur de sécurité :

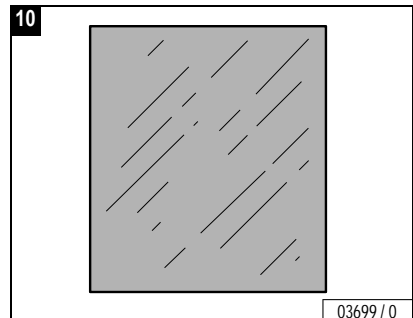
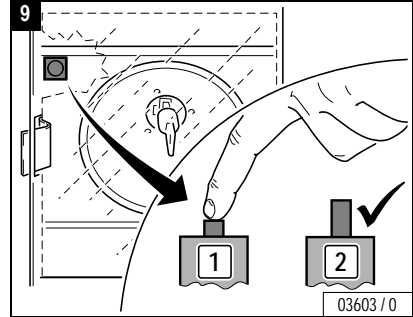

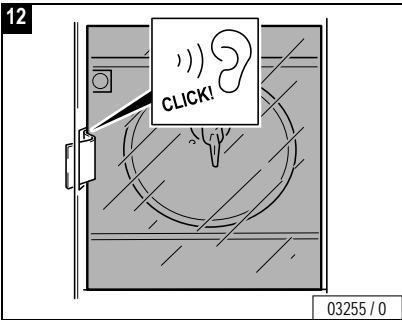
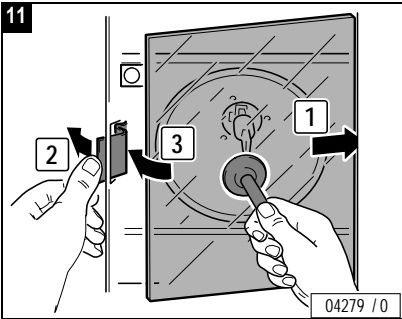

Fermer :

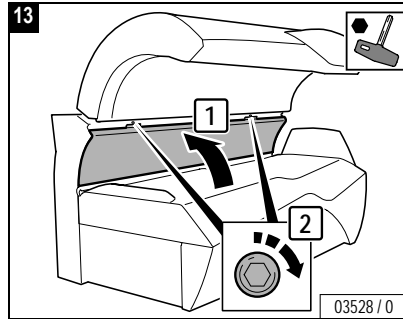



Partie supérieure, lampes à décharge UV haute pression

F

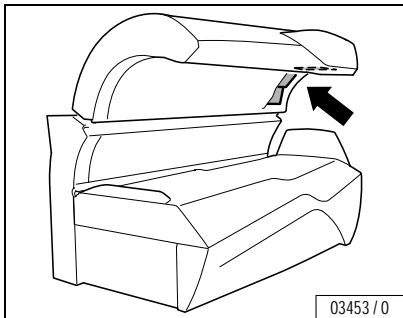
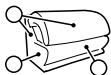

**Mettez l'appareil
hors tension !**

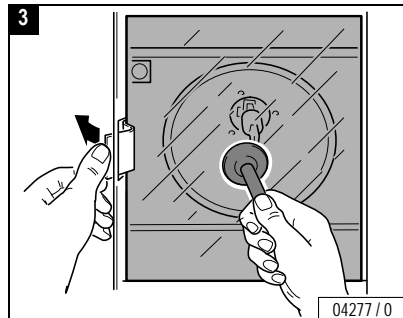
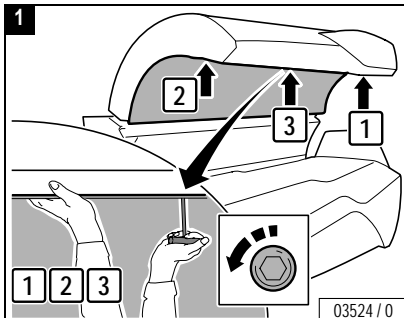

**Danger de blessures par la
partie supérieure !**

Avert. !

La partie supérieure est lourde et
tombe d'elle-même quand les
3 vis sont desserrées.

- Etayez la partie supérieure.
- Desserrez les vis dans l'ordre
indiqué.

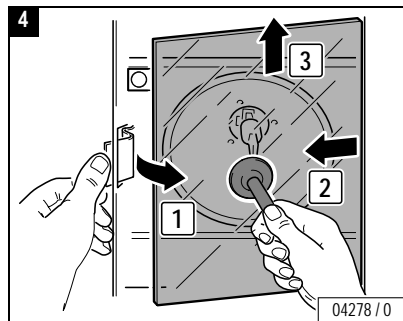
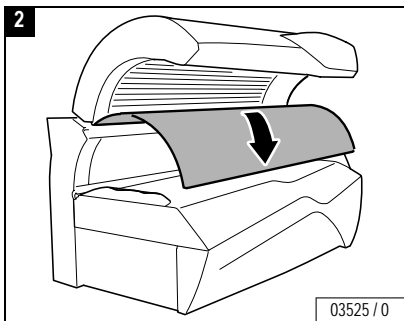

Maintenance

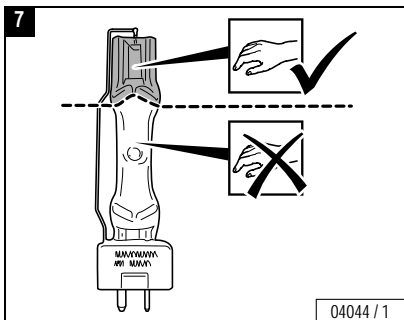
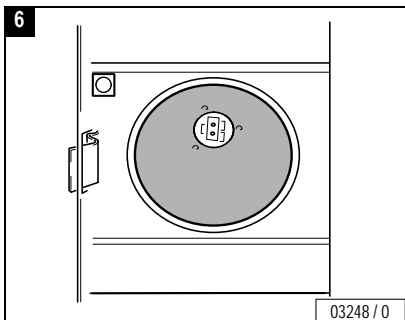
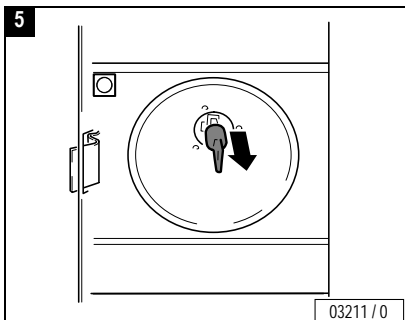

ATTENTION !

Ne touchez pas aux ampoules de verre des lampes UV haute pression avec les doigts nus ! Enlevez soigneusement les salissures.

- Ne touchez la nouvelle lampe UV haute pression que sur la surface de saisie – cf. figures 7 et 8.

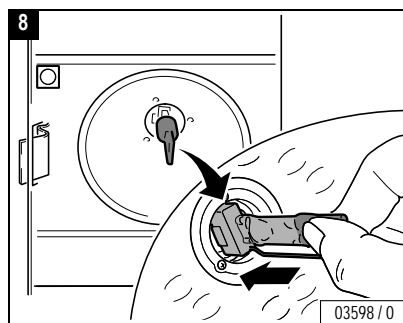

- Vérifiez l'interrupteur de sécurité :

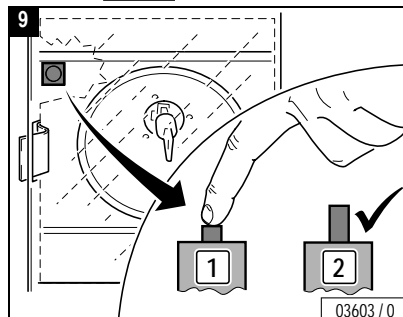

...

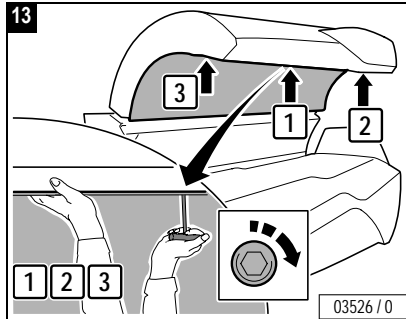
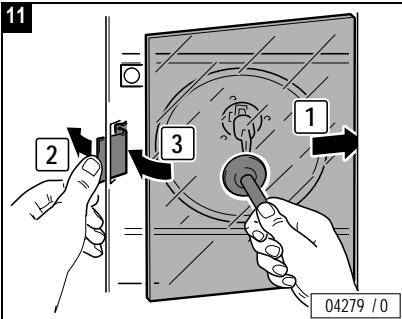
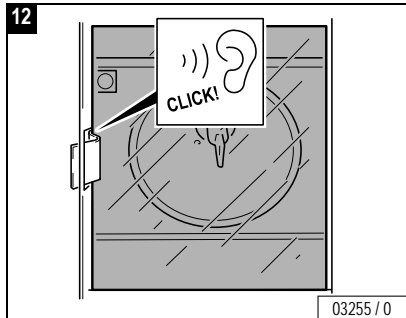
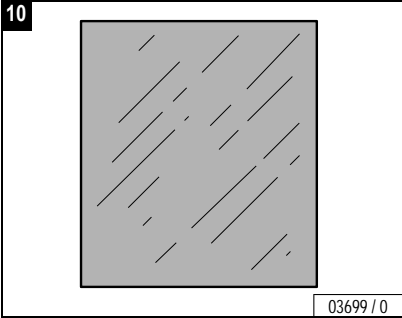

Fermer :





Éclairage de décoration, partie supérieur

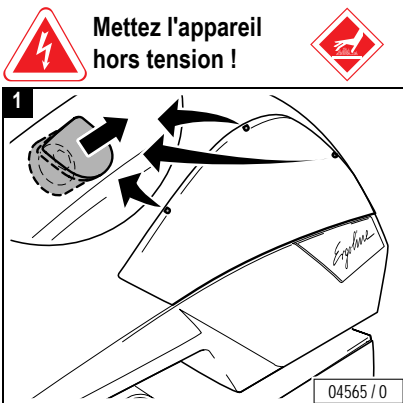
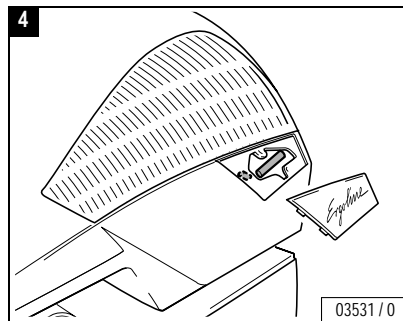
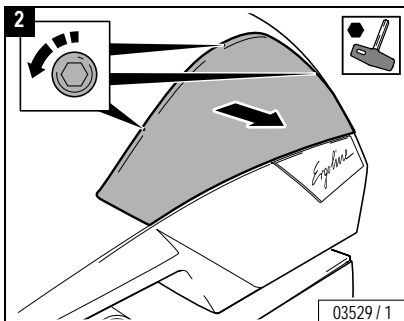
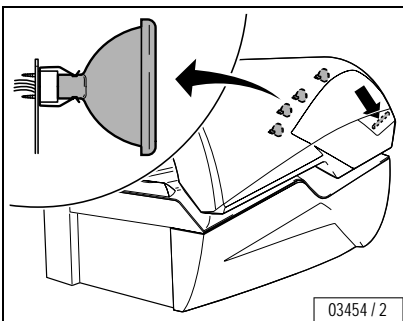
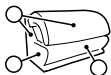

Mettez l'appareil hors tension !

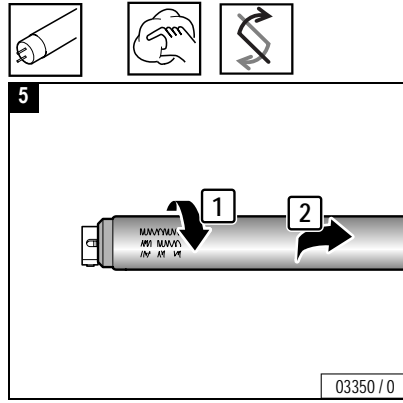
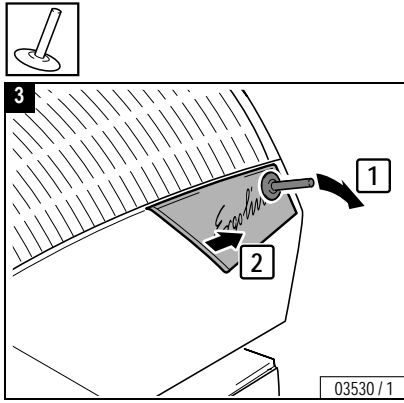

Maintenance

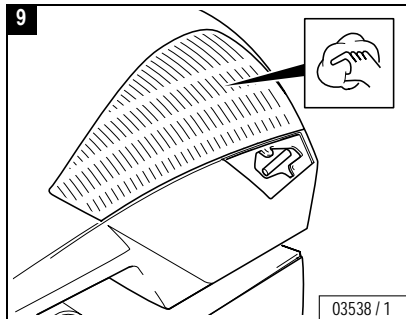
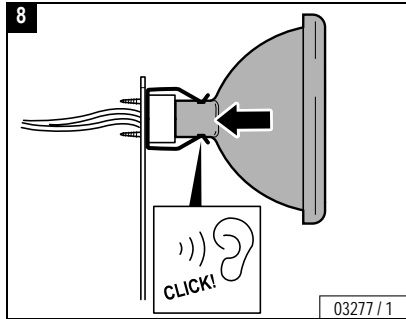
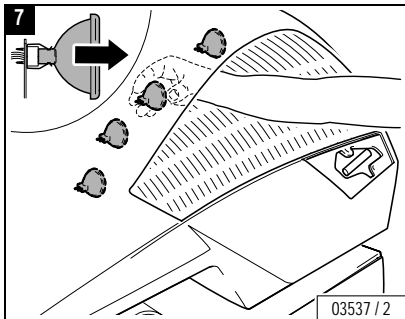
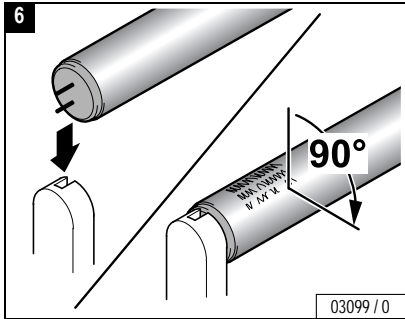

Fermer :

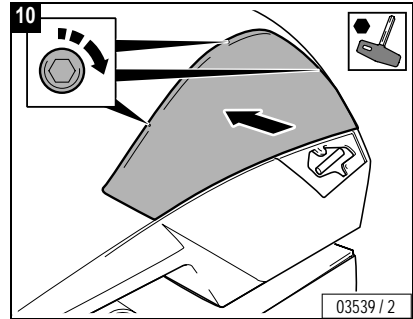

Maintenance

...

F



Maintenance

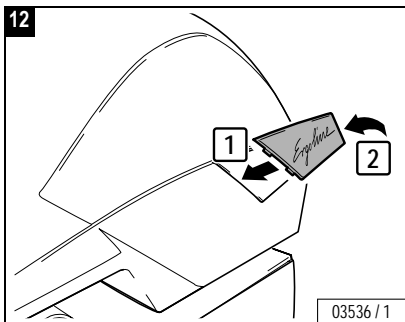
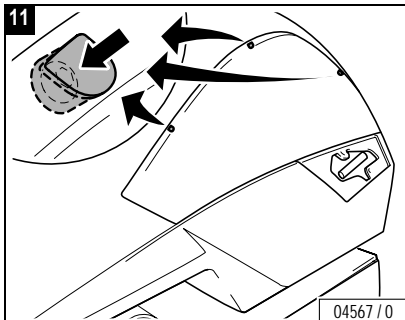



Éclairage de décoration, panneau frontal

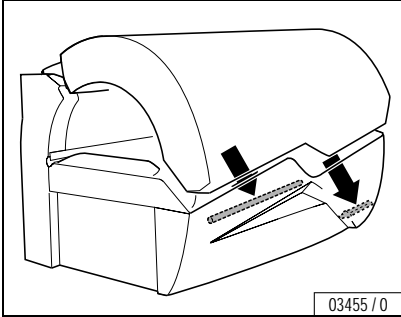
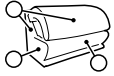

03455 / 0



Mettez l'appareil hors tension !

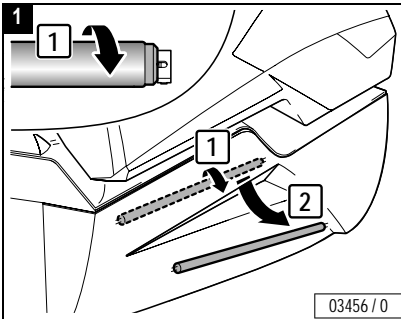

03456 / 0

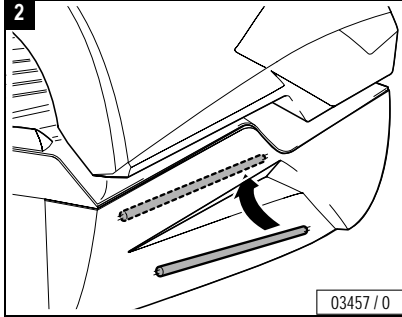

03457 / 0

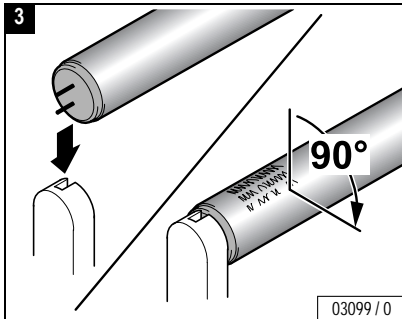

03099 / 0

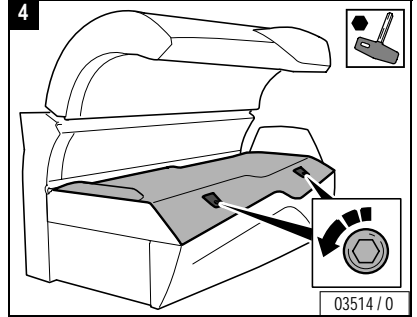

03514 / 0

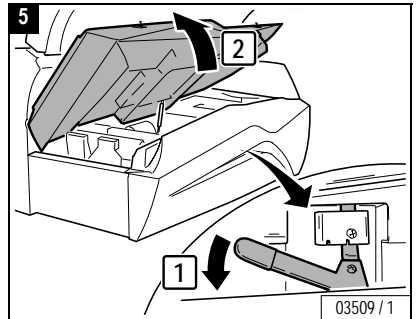

03509 / 1

Maintenance

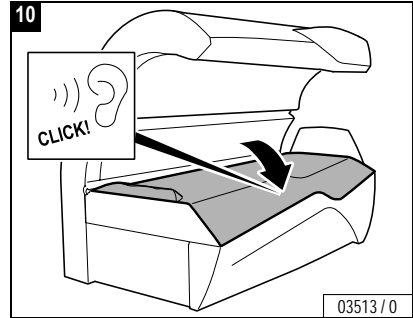
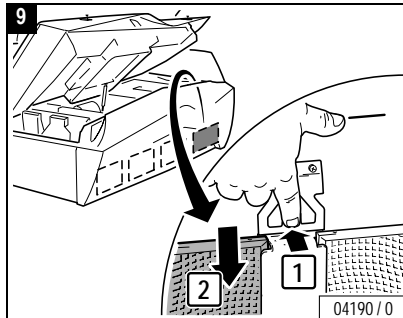
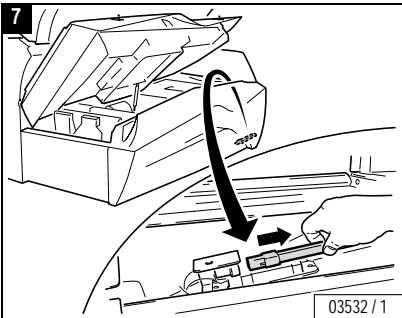
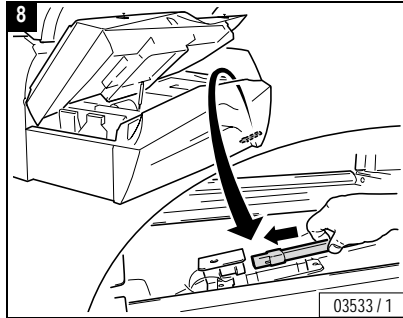
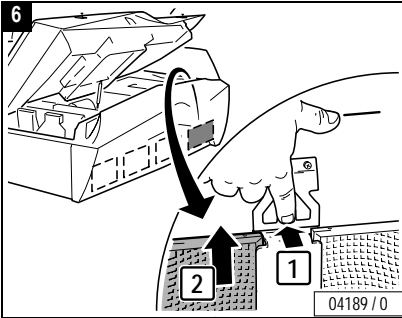

Fermer :

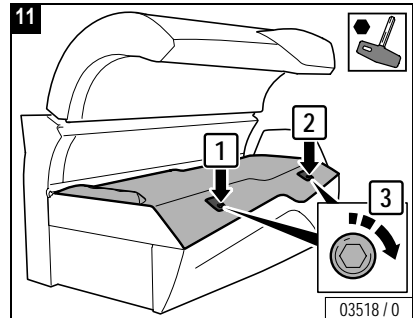



Partie inférieure, filtres

F

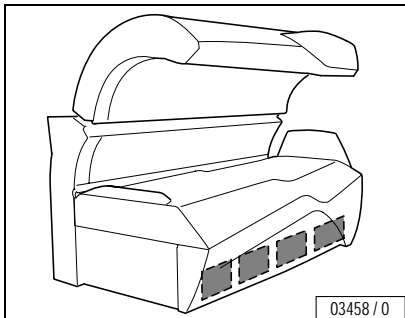
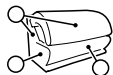

Mettez l'appareil hors tension !

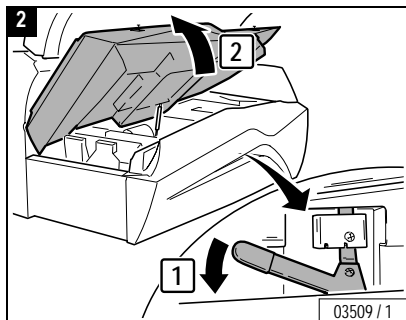
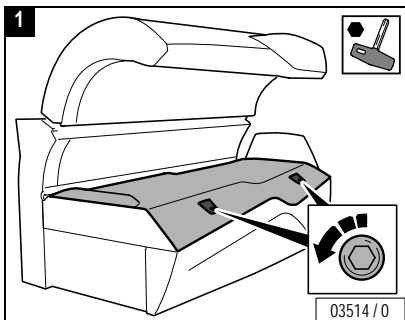

Essuyez légèrement, à sec ou avec de l'eau, ou utilisez un aspirateur.

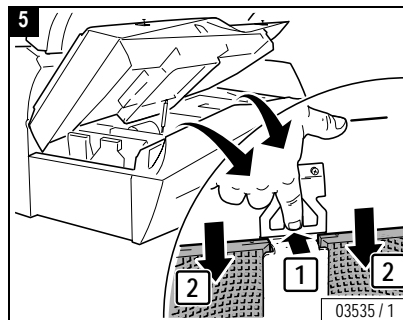
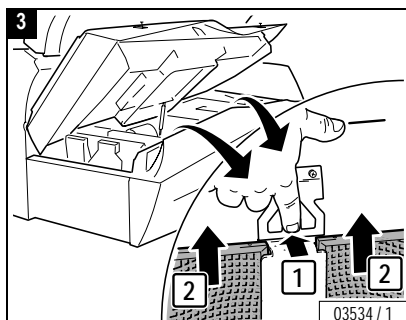
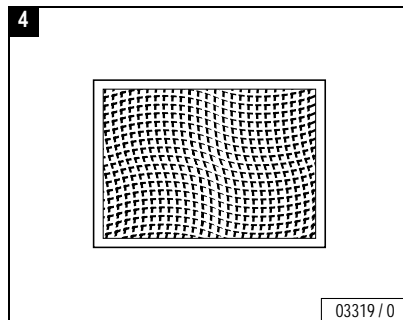

Maintenance 

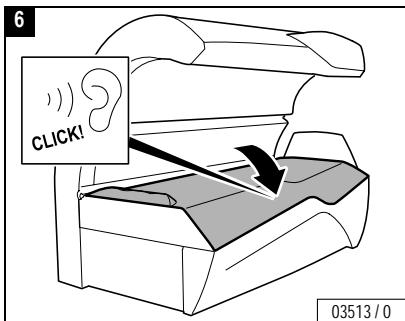

Fermer :

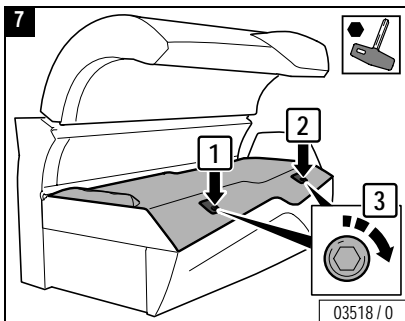



Partie supérieure, nattes filtrantes

F

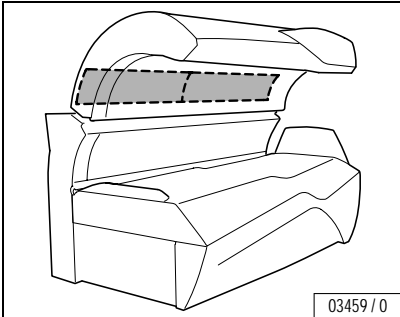
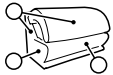

Rincez à l'eau ou remplacez.

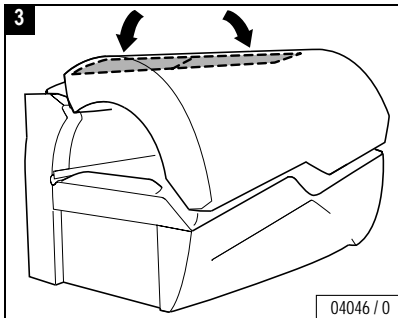
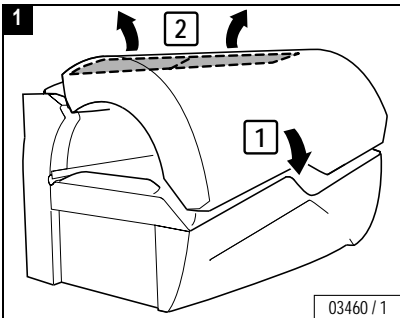
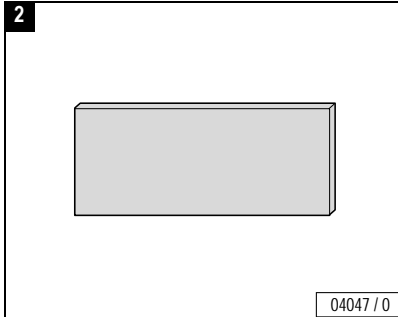

Maintenance





Lampes solaires pour épaules, nattes filtrantes

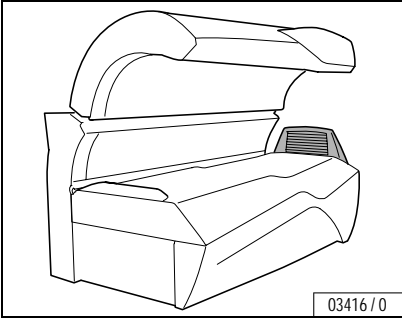
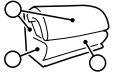

03416 / 0

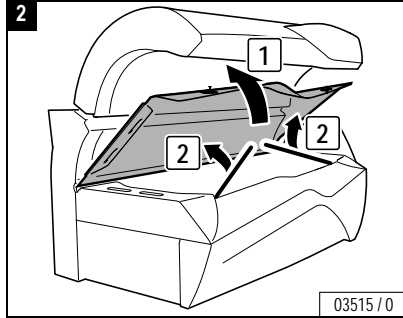

03515 / 0

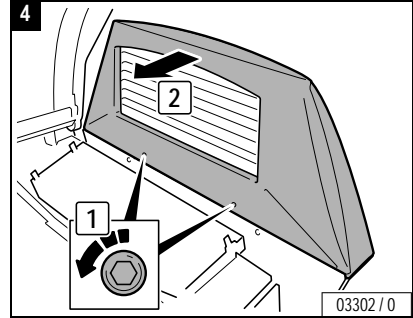

03302 / 0

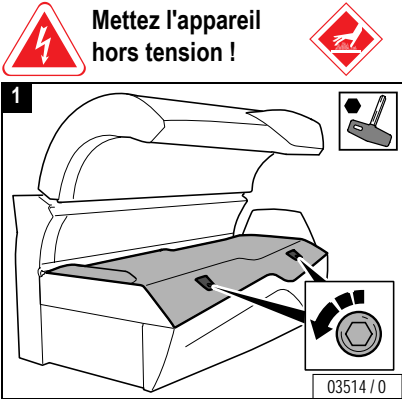

03514 / 0

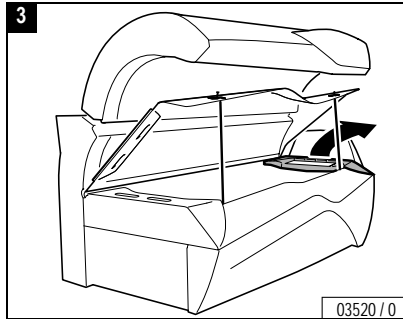

03520 / 0

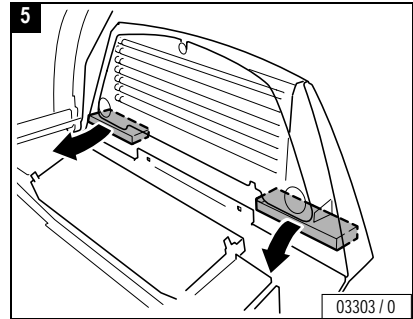

03303 / 0

...

Maintenance



Mettez l'appareil hors tension !





Rincez à l'eau ou remplacez.

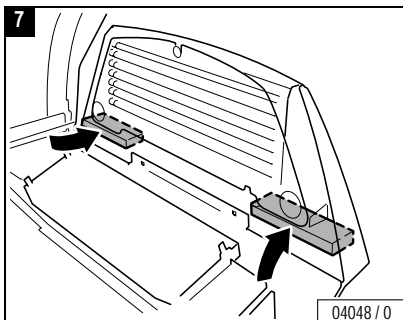
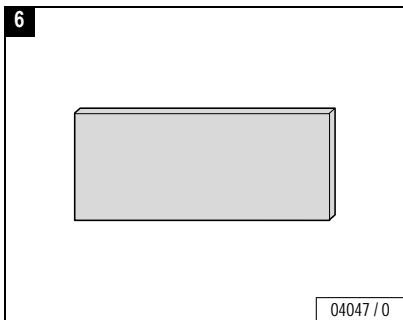

Fermer :

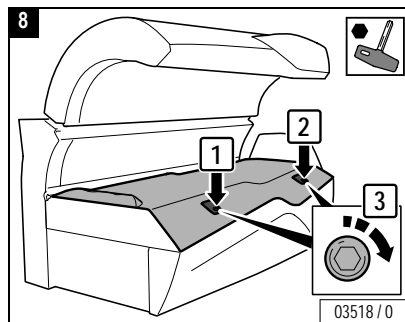

Maintenance 





Système d'air conditionné, eau de condensation et natte filtrante

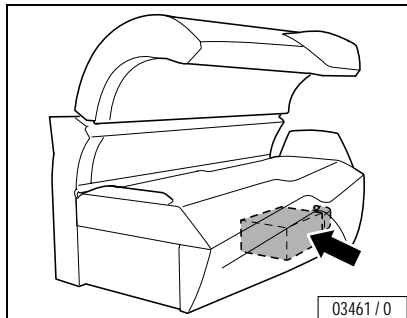
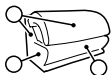

03461 / 0

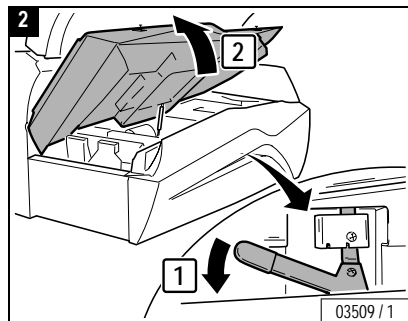

03509 / 1

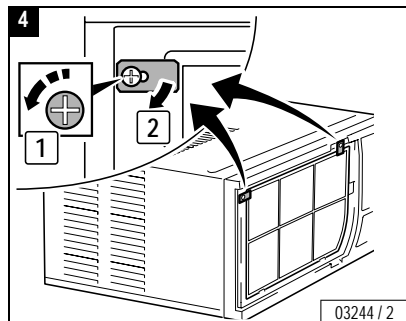

03244 / 2

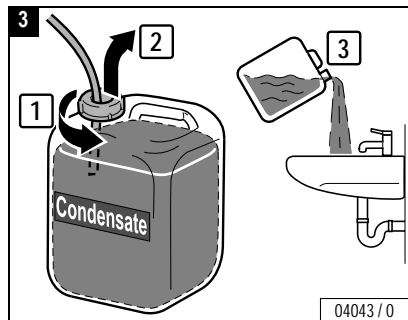

04043 / 0



Nettoyez avec soin (aspirateur ou lavage) ou remplacez.

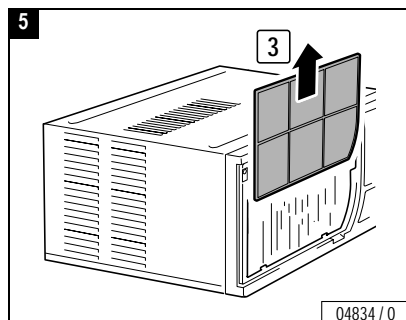

04834 / 0 ...

Maintenance



Mettez l'appareil hors tension !

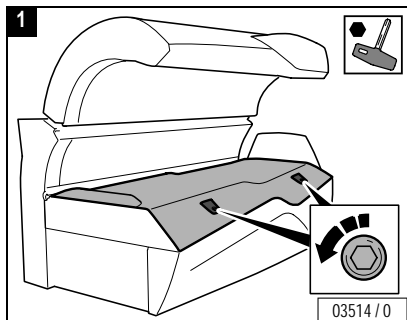

03514 / 0



Fermer :

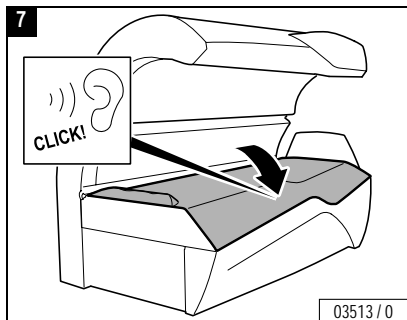
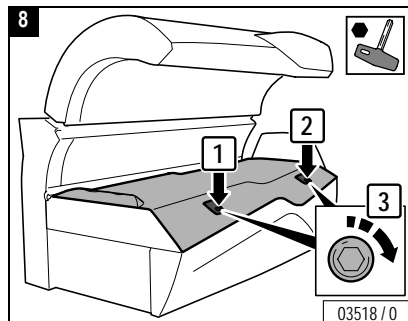
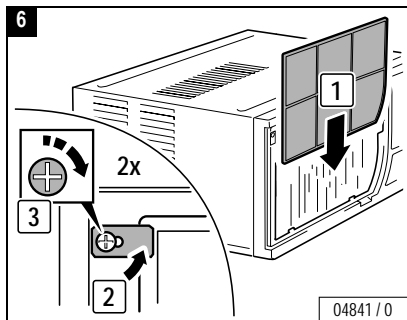





Réglages préliminaires via le tableau de commande

Le mode de réglages préliminaires permet de visualiser les états de fonctionnement et de procéder aux réglages préliminaires. Si l'appareil est équipé de l'assistance vocale (VoiceGuide), vous avez aussi la possibilité d'écouter les explications y afférentes.

Activer le mode de réglage préliminaire

- En dehors d'une séance de bronzage, appuyer simultanément sur les touches – et + pendant au moins 5 secondes.
- L'écran affiche alors .
- Saisir le code (voir page 165).
- Lors de la première activation du mode de réglage préliminaire, actionner 4 fois la touche START/STOP.
-  est d'abord affiché brièvement, puis en alternance  (fonction 1) et la valeur de pré-réglage (voir la colonne « A la livraison »).
- Appuyer sur la touche + pour passer à la fonction suivante (de -01- à -19-).
- Appuyer sur la touche – pour passer à la fonction précédente (de -19- à -01-).

Modifier les réglages préliminaires

Pour augmenter la valeur pré-réglée :

- Maintenir la touche START/STOP enfoncée et appuyer simultanément sur la touche +.

Pour diminuer la valeur pré-réglée :

- Maintenir la touche START/STOP enfoncée et appuyer simultanément sur la touche –.

Pour revenir à la dernière valeur réglée :

- Appuyer sur la touche START/STOP.

Pour réinitialiser l'appareil à l'état à la livraison :

- Voir fonction .



Remarque :





L'unité retournera automatiquement en mode veille après 30 secondes si vous n'avez actionné aucune autre touche. Les valeurs de réglage actuelles sont reprises.

Modification des valeurs :

Les réglages préliminaires sont indiqués à partir de la page 167.



Définir un code

- Sélectionner la fonction .
- Actionner la touche START/STOP pendant 3 secondes jusqu'à ce que l'écran affiche .
- Appuyer sur les touches souhaitées.
- Lorsque  est à nouveau affiché, répéter la saisie dans le même ordre.
- L'écran affiche alors . Le nouveau code a été mémorisé.
- Noter le code à l'intention du service après-vente.

Une nouvelle combinaison peut être définie à tout moment si l'ancien code est connu.



Réglages préliminaires à l'aide d'un ordinateur de poche

Vous avez également la possibilité d'utiliser un ordinateur de poche de type courant (de la marque Palm par exemple). Le logiciel requis (disponible en allemand et en anglais) peut être téléchargé sous www.sunergoline.com. Vous y trouverez également le guide de l'utilisateur correspondant.



Attention !

Le code d'accès via l'interface infrarouge, pré-configuré dans le logiciel, est valable quel que soit l'appareil. Ce logiciel, disponible sur Internet, permet à toute personne disposant d'un ordinateur de poche d'accéder aux données des appareils. Veillez par conséquent à ce que les techniciens de maintenance modifient le code d'accès prédéfini lors de la première mise en service – Voir le guide de l'utilisateur du logiciel. Notez le nouveau code pour une utilisation ultérieure !

Ce code est indépendant du code d'accès aux réglages préliminaires via le tableau de commande.



Remarque :

La procédure à suivre pour la lecture ou la modification des données est indiquée dans le guide de l'utilisateur du logiciel.

Pour l'utilisation de l'ordinateur de poche, se reporter à la documentation du fabricant.

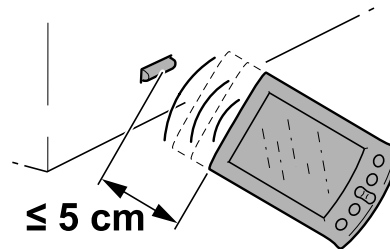



IR Function

04002 / 0



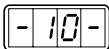
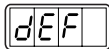
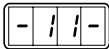
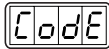
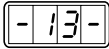
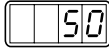
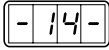
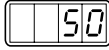
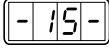

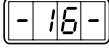
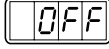
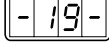
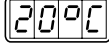
N°.	Description	à la livraison	Valeurs de - à
	Compteur totaliseur durée de fonctionnement		0 → 9999
	Durée restante des lampes à décharge UV basse pression (heures)		500 → 0000
	Durée restante des lampes à décharge UV haute pression (heures)		500 → 0
	Durée restante des lampes solaires pour épaules (heures)		500 → 0
	Durée restante du filtre (heures)		50 → 0
	Heures de service du système d'air conditionné		0 → 9999
	Durée de l'éclairage de décoration (minutes) En cas de dépassement de la valeur maximale : affichage = fonctionnement continu		1 → 1440
	Temps de poursuite du ventilateur d'appareil (minutes)		3 → 10
	Réglage de l'heure		1 → 23 01 → 59

N°.	Description	à la livraison	Valeurs de - à
	Réinitialisation de l'appareil à l'état à la livraison (toutes les fonctions)		
	Réglage de l'autorisation d'accès au mode de pré-réglage (voir page 165)		
	Réglage du volume pour la sortie vocale (VoiceGuide)		7 → 63
	Réglage du volume pour la musique (SoundSystem)		7 → 63
	Valeur de consigne de la température ambiante (°C)		15 → 30
	Retour de l'air chaud pendant le temps de poursuite du ventilateur (+ = on / - = OFF)		
	Température minimale appareil de climatisation		15°C → 25°C



Défauts, causes et dépannage

En cas de dysfonctionnement, des codes d'erreur apparaissent sur l'afficheur de manière à faciliter la localisation des pannes:

- En cas de défaillance, le code d'erreur clignote.
- Lorsque plusieurs défauts surviennent, les messages d'erreur sont affichés en alternance.
- Sur les solariums équipés de , il est possible d'activer les messages vocaux se rapportant aux défauts affichés en actionnant la touche .
- La touche  permet de valider le dépannage.

Si le défaut ne peut pas être éliminé, contacter le service après-vente.



Global Service Division









#1 Walter Kratz Drive

Jonesboro, Arkansas 72401

 (800) 445 0624



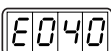
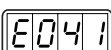

Erreur	Description	Dépannage
	Réservoir de condensat plein (uniquement en cas d'utilisation du réservoir de condensation d'origine)	Vider le réservoir de condensation.
	Panne de pompe à condensat	
	Capteur de température chauffage (système d'air conditionné)	
	Capteur de température refroidissement (système d'air conditionné)	
	Défaut capteur de température des lampes à décharge UV basse pression	
	Sonde de température locale	
	Interrupteur à disque lampes solaires pour épaules	
	Interrupteur à palette n'est pas enclenché alors que le ventilateur marche	
	Interrupteur à palette n'est pas désenclenché 1 minute après déclenchement du ventilateur	
	Défaut bronzeur facial AV	





Erreur	Description	Dépannage
	Contrôleur de bronzeurs faciaux	
	Régulateur de vitesse 1	
	Régulateur de vitesse 2	
	Amplificateur audio	
	Sélection du canal	
	Horloge	
	Mémoire paramètres	
	Mauvais équipement de la commande	

Index alphabétique

Index alphabétique

A

Aperçu

Maintenance 128
 Service 110

B

Blessures aux yeux..... 98

C

Caractéristiques techniques 124
 Changer les lampes
 Bronzeurs pour nuque 137
 Lampes solaires pour épaules 139
 Charge maximale autorisée..... 125
 Cleaning schedules 128
 Codes d'erreur 169
 Conséquences à long terme 99
 Consommation..... 124
 Contact 109
 Coupe-circuits..... 127
 Couper la tension..... 127
 Crème solaire 108

D

Début de la séance de bronzage..... 112
 Defaults 169

Définir un code, Réglages préliminaires ... 165
 Durée de fonctionnement des lampes
 décoratives..... 114
 Durées de bronzage..... 93

E

Éclairage de décoration dans la partie
 supérieure, changer 152
 Éclairage de décoration dans le panneau
 frontal, changer 155, 156
 Éclairage intérieur, changer 144
 Enfants..... 99
 Equipement 104
 Étiquette du type d'appareil..... 92
 Evacuation des lampes 107
 Exportation..... 104

F

Filtres dans la partie inférieure, nettoyer... 157
 Fonctionnement
 Bronzeur pour épaules 116
 Bronzeurs faciaux..... 115
 Canal musical..... 122
 INFO..... 121
 Voice Guide..... 120
 Volume 123

Fréquence 124

G

Global Service Division 92

I

Information relative à la sécurité 93, 98
 Instructions relatives au remplacement des
 lampes, généralités 134
 Intervalles de maintenance 130
 Lampes UV 132

L

Lampes à décharge UV basse pression
 (Changer)
 Bronzeurs pour nuque 137
 Lampes solaires pour épaules..... 139
 Partie inférieure 135
 Partie latérale 141
 Partie supérieure 142
 Lampes à décharge UV haute pression
 (Changer)
 Partie latérale 146
 Partie supérieure 149
 Lampes solaires pour épaules
 Nattes filtrantes..... 160

M

Mineurs	99
Modifier les réglages préliminaires	164

N

Natte filtrante du système d'air conditionné, nettoyer/changer	162
Nattes filtrantes dans la partie supérieure, nettoyer/changer	159
Nattes filtrantes des lampes solaires pour épaules, nettoyer/changer	160
Notice de bronzage.....	107
Numéros de commande	130, 131, 132

O

Opérateur, information importante	98
-----------------------------------------	----

P

Panneaux en verre acrylique	105
Panneaux filtrants, nettoyer	148, 151
Pièces détachées	105
Plan d'exposition.....	93
Plastique	106
Pour interrompre la séance de bronzage .	113
Poursuite du ventilateur	112
Pouvoir de coupure nominal	124
Puissance consommée.....	124

R

Refroidissement du corps	117, 118
Réglages pendant le démarrage.....	113
Réglages préliminaires.....	164, 167

S

Symboles	101
Appuyer sur le bouton	102
Clé Ergoline.....	101
Contrôle visuel.....	103
Filtre/natte filtrante.....	103
Interrupteur de sécurité	102
Lampe basse pression	101
Lampe haute pression.....	101
Nettoyage	103
Panneau filtrant	101
Remplacement	103
Starter.....	101
Surface chaude	101
Vidage	103

Système d'air conditionné

Maintenance.....	162
Utilisation.....	117

T

Température / humidité ambiantes maximum	125
Temps de préparation	112
Temptronic Maintenance	162
Utilisation	117
Tension.....	124
Tolérance solarium dans la pièce.....	125
Types de peau.....	108

U

UL Standard	104
Utilisation conforme	98

V

Ventilation.....	108
Vider le réservoir à condensation	162

Garantie limitée SUN Ergoline

SUN Ergoline garantit pendant une durée de trois (3) ans à partir de la date de l'achat que ses produits sont libres de toute non-conformité de matériau et de main-d'oeuvre pour une utilisation normale telle qu'elle est décrite dans le Manuel de manipulation et d'instructions de l'unité.

La garantie limitée est valable pour l'acquéreur d'origine de l'équipement par les soins de SUN Ergoline ou du vendeur ou distributeur autorisé ; elle n'est pas transférable.

Les obligations de SUN Ergoline au titre de la présente garantie sont limitées à la réparation ou le remplacement des pièces non conformes sans charge pour ladite pièce pour l'acquéreur d'origine, avec les exceptions suivantes :

- A. Les lampes fluorescentes sont garanties contre les défauts pendant une période de trente (30) jours à partir de la date de l'achat.
- B. Seules peuvent être utilisées les pièces acquises auprès de SUN Ergoline, de ses revendeurs et distributeurs autorisés. Les frais de transport pour les pièces expédiées l'acquéreur et le retour des pièces défectueuses à SUN Ergoline ne sont pas compris.
- C. Les travaux sont uniquement délivrés sans charge pendant une durée de quatre-vingt dix (90) jours à partir de la date de l'achat. Tous les travaux et frais en relation avec ceux-ci doivent être autorisés par SUN Ergoline avant de commencer la réparation et doivent être conformes aux barèmes et à la pratique de répartition dans le temps établis par SUN Ergoline.

D. Matériau acrylique : Selon la pratique de garantie du fabricant du matériau acrylique.

Il est absolument indispensable que l'acquéreur d'origine remplisse et retourne la carte de garantie incluse dans les 10 jours après l'achat pour assurer un enregistrement valable et la couverture des recours éventuels.

Si la carte de garantie n'est pas enregistrée, le recours en garantie ne sera pris en considération qu'après établissement de la preuve d'un achat auprès de SUN Ergoline ou d'un vendeur ou distributeur agréé par celle-ci. Cette procédure peut entraîner un retard du service.

La garantie est élargie à la personne physique ou morale dont le nom apparaît sur la carte d'enregistrement déposée auprès de SUN Ergoline, ou dont le nom apparaît dans le document de vente original ; elle ne peut pas être transférée à une autre personne physique ou morale.

La présente garantie ne s'applique pas dans les cas de défaillance du produit ou d'une pièces quelconque du produit due à des altérations, des modifications, des utilisations interdites, des accidents, une maintenance non conforme, une installation non conforme, les catastrophes naturelles, ou si le numéro de série sur le produit a été changé, altéré ou effacé. Un emballage adéquat sera utilisé pour retourner les pièces afin de prévenir les dommages.

Il n'existe pas de garantie au delà de celle décrite ci-dessus. Il n'y a pas de garantie expresse ou implicite de bon fonctionnement et de valeur loyale et marchande.

Les prestations accordées au titre de la présente garantie limitée sont les seules prestations délivrées à l'acquéreur par SUN Ergoline et sont accordées à titre de substitution par rapport à toutes les autres prestations. Les dommages consécutifs et incidents sont exclus.

Personne, aucune société ni aucun établissement ne peut obliger SUN Ergoline à un titre quelconque pour l'acquisition ou l'utilisation des choses ci-dessus.

Garantie limitée du matériau acrylique

SUN Ergoline garantit pendant une durée de un (1) an à partir de la date d'achat du solarium que les panneaux acryliques sont exempts de toute non-conformité de matériau et de main-d'œuvre, pour une utilisation normale. Cette garantie ne s'étend pas aux altérations dues aux lotions de solarium, produits cosmétiques, désinfectants et agents de nettoyage non conformes appliqués sur les surfaces du solarium et ne pouvant pas être contrôlés par SUN Ergoline au delà de la première période de garantie de trente (30) jours. Le verre acrylique sera facturé à un montant proportionné aux frais de l'acquéreur en cas de bris.

Les obligations de SUN Ergoline ne s'étendent pas aux frais de transport et au remplacement de la surface acrylique.

SUN Ergoline n'endosse aucune responsabilité pour les frais de démontage des feuilles et l'installation des feuilles de rechange, ni pour les dommages aux personnes et aux biens.

Pour tout recours en garantie, contactez le vendeur ou le distributeur autorisé de SUN Ergoline ou le Global Service Division en mentionnant le numéro du modèle, le numéro de série et la date de l'acquisition de la banquette sur laquelle la surface acrylique est utilisée.

Il n'existe pas de garantie au delà de celle décrite ci-dessus. Il n'y a pas de garantie expresse ou implicite de bon fonctionnement et de valeur loyale et marchande.

Les prestations accordées au titre de la présente garantie limitée sont les seules prestations délivrées à l'acquéreur par SUN Ergoline et sont accordées à titre de substitution par rapport à toutes les autres prestations. Les dommages consécutifs et incidents sont exclus.

Global Service Division

#1 Walter Kratz Drive

Jonesboro, Arkansas 72401

☎ (800) 445 0624

Recours en garantie

Pratique et procédure

1. Pour une demande de recours en garantie

Si votre solarium ne fonctionne pas correctement dans les conditions normales d'utilisation décrites par le Manuel de manipulation et d'instructions de l'unité, vous pouvez déposer une demande de recours en garantie.



NOTE : Préalablement à toute prise en considération de la demande de recours en garantie, le solarium et le propriétaire légalement enregistré doivent satisfaire aux critères de garantie limitée de SUN Ergoline du présent manuel.

2. A qui s'adresser pour une demande de recours en garantie :

SUN Ergoline entretient un réseau étendu de vendeurs et de distributeurs nationaux dans la plupart des pays où sont vendues les unités. Ces vendeurs et distributeurs sont tenus par contrat de tenir en magasin une réserve suffisante de pièces pour couvrir les différentes nécessités de la garantie et des réparations hors garantie pour leurs clients.

Toutefois, pour adresser correctement votre recours en garantie, vous devez être en possession du nom et du numéro de téléphone du vendeur ou du distributeur auprès duquel vous avez acquis votre unité. Normalement, cette information est facile à trouver sur votre facture ou autre document établissant la vente et que vous avez reçu à la livraison de l'unité.

Ensuite, communiquez au vendeur ou au distributeur le numéro de série, le numéro de modèle et la date à laquelle l'unité a été acquise. La procé-

dure de recours en garantie est alors engagée.

Jusqu'à ce que le problème soit localisé, votre vendeur ou distributeur peut vous approvisionner avec la ou les pièces et vous donner les instructions appropriées pour retourner votre unité avec un ordre de travail.

Chaque vendeur et distributeur applique une procédure qui lui est propre pour le suivi des recours et des crédits en garantie.

NOTE : Le fabricant SUN Ergoline n'intervient pas lui-même dans le suivi direct du recours en garantie, sauf les cas de litiges et les cas dans lesquels cette intervention est requise par la loi.

Recours en garantie sur les pièces / Revue de crédit

1. L'acquéreur appelle SUN Ergoline et notifie le problème au Département Service.
2. Le Département Service de SUN Ergoline fixe la marche à suivre.
3. SUN Ergoline expédie les pièces et R.A.I. à la charge de l'acquéreur pour le fret et établit la facture payable à 30 jours nets, uniquement pour les pièces.
4. Dans les 15 jours suivant la nouvelle pièce, l'acquéreur retourne la pièce défectueuse à SUN Ergoline avec R.A.I.
5. Jusqu'à la réception de la part défectueuse et du R.A.I., SUN Ergoline établit un débit de crédit à l'ordre de l'acquéreur compensant le montant de la facture originale. Le compte de l'acquéreur est remis à zéro pour ce qui concerne ce recours.



NOTE : S'il s'avère que la pièce retournée à SUN Ergoline est opérationnelle et ne présente pas de défaut ou si le numéro de la pièce n'est pas identique aux informations de l'unité individuelle sur le fichier de SUN Ergoline, un supplément de 30% sera facturé en plus du prix de vente au détail de la pièce.

Il n'est pas nécessaire que la présente convention ait été agréée pour que les conditions ci-dessus s'appliquent.

Recours en garantie de travail / Procédures de crédit

SUN Ergoline fournit le travail sans frais pendant une durée de 90 jours à partir de la date de l'achat. Tous les travaux et frais en relation avec ceux-ci doivent être autorisés par SUN Ergoline avant de commencer la réparation et doivent être conformes aux barèmes et à la pratique de répartition des travaux dans le temps établis par SUN Ergoline.

Veuillez contacter notre Département Service pour l'authentification et les procédures de facturation.

Garantie

Garantie limitée pendant la durée de vie utile

SUN Ergoline garantit les composantes spécifiques individuelles du solarium professionnel contre les non-conformités de matériau et de main-d'œuvre pendant la durée de vie utile du produit. Cette garantie est limitée aux unités qui ont été acquises après le 1^{er} novembre 1994.

La présente garantie est limitée aux composantes ci-dessous :

- Les panneaux arrière en acier
- Les composantes des structures de cadre d'acier
- Le corps extérieur d'acier



NOTE : La garantie pour lesdites composantes s'entend sur une base individuelle et n'est pas valable pour le produit complet.

Ladite garantie n'inclut pas les anomalies esthétiques telles que les rayures, les entailles, les dents, l'oxydation de la peinture ou autres modifications esthétiques qui n'ont pas d'incidence sur le fonctionnement de l'unité tel qu'il est prévu.

Ladite garantie ne s'étend pas aux défaillances du produit dues au vieillissement, aux modifications, aux erreurs de manipulation, aux erreurs de maintenance, aux erreurs d'installation et de réparation.

Ladite garantie n'est pas transférable, elle est valable uniquement pour l'acquéreur d'origine dont le nom est transmis et inscrit sur le registre de garantie du quartier général de SUN Ergoline.

Les obligations de SUN Ergoline ne s'étendent pas aux frais de transport pour l'expédition de composantes nouvelles à l'acquéreur ni au retour au fabricant des pièces défectueuses. L'acquéreur supporte toutes les dépenses de fret.

Il n'existe pas de garantie au delà de celle décrite ci-dessus. Il n'y a pas de garantie expresse ou implicite de bon fonctionnement et de valeur loyale et marchande.

Les prestations accordées au titre de la présente garantie limitée sont les seules prestations délivrées à l'acquéreur par SUN Ergoline et sont accordées à titre de substitution par rapport à toutes les autres prestations. Les dommages consécutifs et incidents sont exclus.



Remarque : Toute utilisation interdite ou abusive, toute modification, altération, maintenance non conforme, installation non conforme, etc., du produit ci-dessus ou de son utilisation normale entraînent la responsabilité directe de l'auteur et la prise en charge de toutes les conséquences qui en résultent. De plus, lesdites actions entraînent la perte de toutes les garanties et libèrent SUN Ergoline de toutes ses obligations concernant ledit produit.



Garantie

Garantie pendant la
durée de vie utile



NO POSTAGE
NECESSARY
IF MAILED
IN THE
UNITED STATES

BUSINESS REPLY MAIL
FIRST-CLASS MAIL PERMIT NO 295 JONESBORO AR

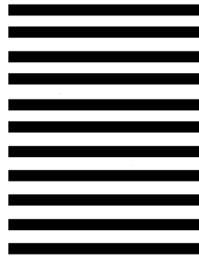

POSTAGE WILL BE PAID BY THE ADDRESSEE

Separate here

SUN ERGOLINE, INC.
#1 WALTER KRATZ DRIVE
JONESBORO, AR 72401



SUN *Ergoline Ergoline soltron* **wellsystem™**



Ergoline Ergoline

soltron

wellsystem™

Ⓐ WARRANTY REGISTRATION

Please complete the warranty section below. To validate and insure proper coverage, card must be completed and returned within ten (10) days of the date of purchase.

_____/_____/_____
Name of Purchaser Date of Purchase

Street Address or P. O. Box

City State Zip

()

Phone Number with area code

Company unit purchased from and amount paid.

Name of Business (if applicable)

Circle Answers: **Sex:** Male Female

Age: 18-29 30-39 40-49 50-59 60+

Annual Household Income:

up to \$15,000 \$15-30,000
\$30-50,000 over \$50,000

Residence: Own Home Rent Other

If you experience any difficulties obtaining replacement parts from your distributor, please call Sun Ergoline at 800-643-0086, choose option 5.

SE Year & Model #

SE Serial #

SUN ERGOLINE INC.

#1 Walter Kratz Drive · Jonesboro, Arkansas 72401 · Phone: 1-800-643-0086 or 870-935-1130 · Internet: www.sunergoline.com

Ergoline